

Sight glass level indicator Model LGG

WIKA data sheet LM 33.01

Applications

- Heat transfer and refrigeration systems
- Plant for cryogenics
- Steam boilers
- Process industries: chemical plants, refineries, offshore, oil and gas, power plants

Special features

- Pressure rating PN 6 ... 250
- Operating temperatures from -200 ... +450 °C
- Carbon steels and stainless steels, suitable for pressure vessels in accordance with EN or ASME

Description

The model LGG sight glass indicator serves as a direct display for fluids and can be fitted with reflex or transparent sight glasses, or with mica. For light-dark contrast, the refraction principle is used. For pressures under 25 bar, a glass tube display is used.

The model LGG sight glass indicator consists of a core in a glass holder, also known as a backplate. Incorporated into this backplate are the fluid channel (and if necessary the heating channel) and the seating face for the integral sealing and sightglasses.

The glasses and/or mica discs as well as the seals are fitted, secured and sealed with the aid of screws and a cover. Glasses are used in accordance with DIN 7081, meaning to max. temperatures of 243 °C (280 °C with mica design) for steam, up to 300 °C for other media, to 450 °C in special circumstances.



Sight glass level indicator model LGG

For the sight glass plates, for glass quality, only borosilicate glass is used. Outside of these operating conditions the natural material mica is used.

The connection to the process is generally made with valve heads with single or double isolation. Drain valves enable the sight glass indicator to be emptied and are fitted to the lower flange face. If necessary, a vent valve can be fitted at the top.

General specifications

| | |
|--------------------------------------|-------------------------------------|
| Visible length VL | ≤ min. centre-to-centre distance ME |
| Glass type ¹⁾ | 2 ... 11 (34 x 17 mm) |
| Operation | Handle or lever |
| Connection of valve head (backplate) | Valve integrated or fitted |
| Valve connecting channel | 8 mm |
| Process connection | Flange DIN or ANSI ²⁾ |
| Drain valve | Ball cock or valve |
| Pressure gauge valve | Single or double isolation |
| Weight | dependent on the design |

1) Other glass types on request
2) or to customer specification

Design Data

| | |
|----------------------------------|--|
| Working pressure | +6 ... +250 bar |
| Operating temperature | -200 ... +450 °C |
| Materials | |
| ■ Sight glass plates | Borosilicate (in accordance with DIN 7081) or Mica |
| ■ Glass holder, cover, backplate | Carbon steel, stainless steel, duplex, monel, inconel, hastelloy, titanium, etc. |
| ■ Connection flange | Carbon steel or stainless steel |
| ■ Drain components | Stainless steel ²⁾ |
| ■ Sealings | Graphite, rubber, PTFE |
| Certificates | Approvals and test certificates to EN 10204, NACE sour gas and customer specifications |

2) for pressure vessels to EN or ASME

Options

| | |
|--------------------------------------|--|
| Pointer | Low-water mark to TRD |
| Accessories for pressure gauge valve | Ball-check valve (at least 1 bar of vessel pressure is required for it to work) - Single or double isolation - Handle or lever |
| Illumination | Filament bulb or fluorescent tube |
| Heating | external or integrated |
| Scale | Engraving to customer requirements |
| Frost protection | from Plexiglass |
| Corrosion resistant glass | Mica plates, FEP Foil |
| Lining/coating | Halar, rubber |
| Glass protection | Mica protection, internal and external |
| Surface protection | seawater resistant, painted or galvanised |

Arrangement (example)

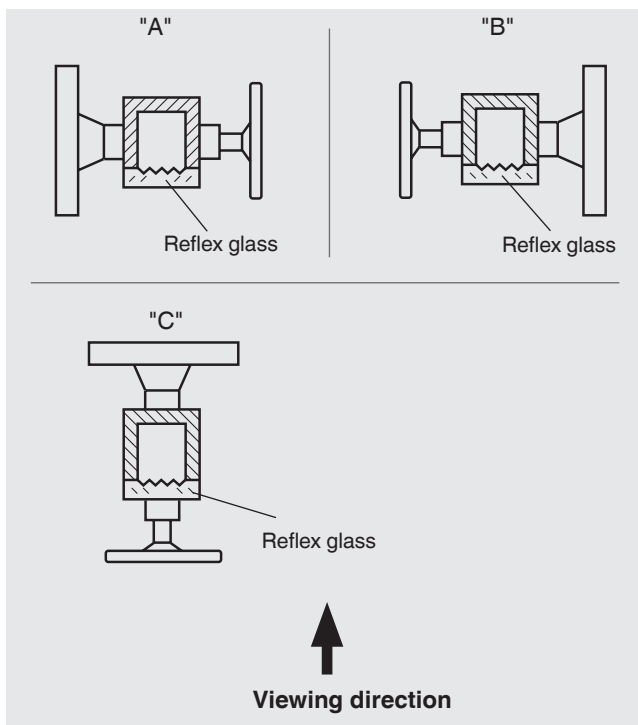

Construction (example)

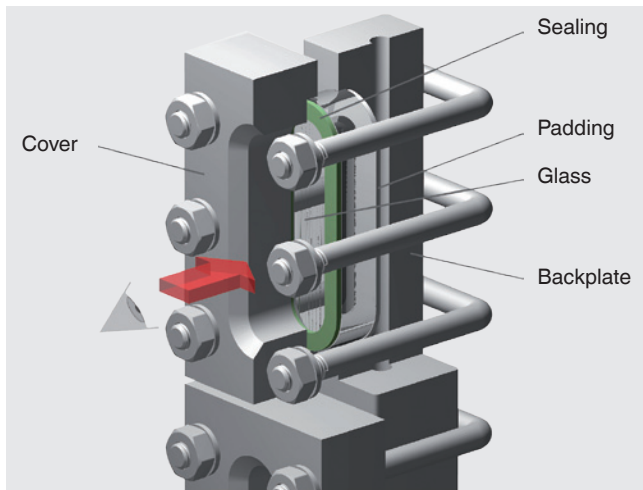

The specifications given in this document represent the state of engineering at the time of publishing. We reserve the right to make modifications to the specifications and materials.

