

Fisher® GX 3-Way Control Valve and Actuator System

The Fisher GX 3-Way is a compact, state-of-the-art control valve and actuator system, designed to accurately control water, oils, steam, and other industrial fluids. The robust GX 3-way valve package is perfectly suited to address the space limitations of the OEM industry.

The GX 3-Way is rugged, reliable, and easy to select. The internal valve trim is designed to ensure long service life and avoiding unnecessary maintenance. The same construction may be used for both converging and diverging applications.

The GX 3-Way meets the requirements of both EN and ASME standards. It is available with a complete accessory package, including the FIELDVUE™ DVC2000 and FIELDVUE DVC6200 integrated digital valve controllers.

The GX 3-Way trim characteristics are designed for accurate temperature control in heat exchanger applications.

- **Side-Port Common (SPC)**--The side flange is the common pipe connection for general converging (flow-mixing) and diverging (flow-splitting) service (see figure 4). Utilizes an unbalanced plug design.
- **Bottom-Port Common (BPC)**--A balanced design used for high pressure drop applications. The bottom flange is the common pipe connection for both converging and diverging service (see figures 8 and 10).
- **High-Temperature Side-Port Common (SPC)**-- The side flange is the common pipe connection for general converging (flow-mixing) and diverging (flow-splitting) service (see figure 2). Utilizes an unbalanced plug design, a stem extension, a yoke extension, and includes ENVIRO-SEAL™ graphite ULF packing (figure 14) and a hard-faced seat ring.



W9557
Fisher GX 3-Way Control Valve, Actuator, and FIELDVUE DVC2000 Digital Valve Controller



GE49204
X0176
Fisher GX 3-Way High-Temperature Control Valve and Actuator



Figure 1. Fisher GX 3-Way Control Valve Assembly with Port-Guided Contoured Plug (Side Port Common)

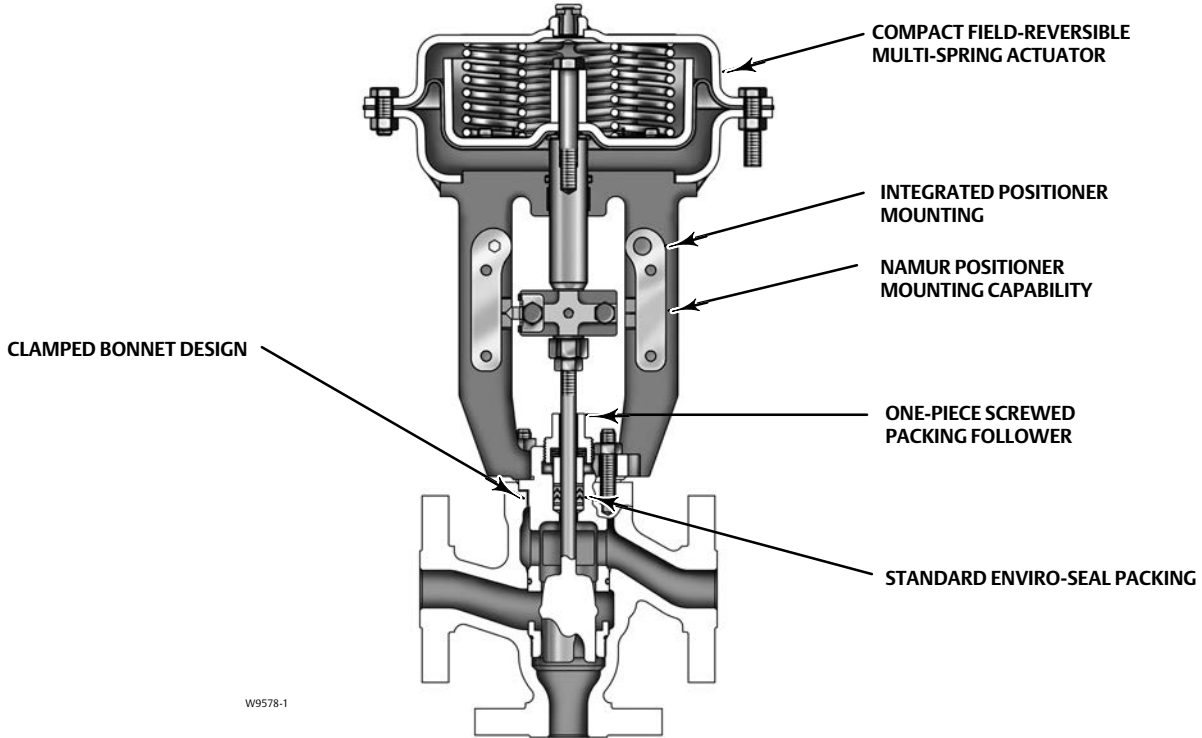
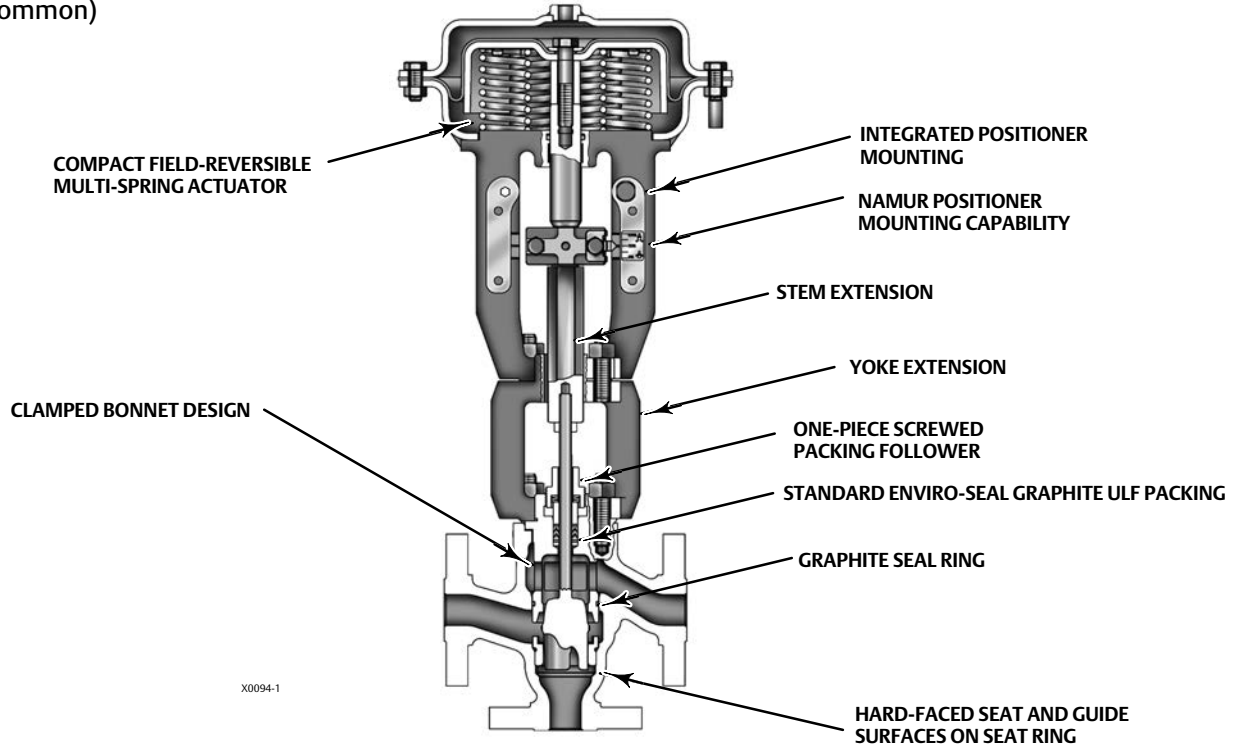

Figure 2. Fisher GX 3-Way High-Temperature Control Valve Assembly with Port-Guided Contoured Plug (Side Port Common)



Features

- Easy to size and select
- No actuator sizing required--selection is automatic
- Engineered for easy maintenance
- Maximum part commonality across sizes
- Replaceable trim
- Low lifetime costs
- Robust, low-profile design
- Available with integrated, easy-to-calibrate DVC2000 or DVC6200 digital valve controller
- Valve body sizes DN 25 to DN 100 (NPS 1 through 4)
- Pressure Classes PN 10-40, CL150 and 300
- High capacity design
- Valve body flow passage optimized for flow stability
- Shutoff capabilities: Class IV metal to metal
- ISO 5210 F7 mounting available for use with electric actuators

Contents

Features	3	Valve-Actuator Dimensions and Weights	17
Principle of Operation	10	GX 3-Way Actuator Accessories	19
GX 3-Way Control Valve Specifications and Materials of Construction	11	The FIELDVUE DVC2000 Digital Valve Controller ..	19
The GX 3-Way Diaphragm Actuator	14	Optional Positioners and Instruments	20

Figure 3. Fisher GX 3-Way and FIELDVUE DVC2000 Digital Valve Controller

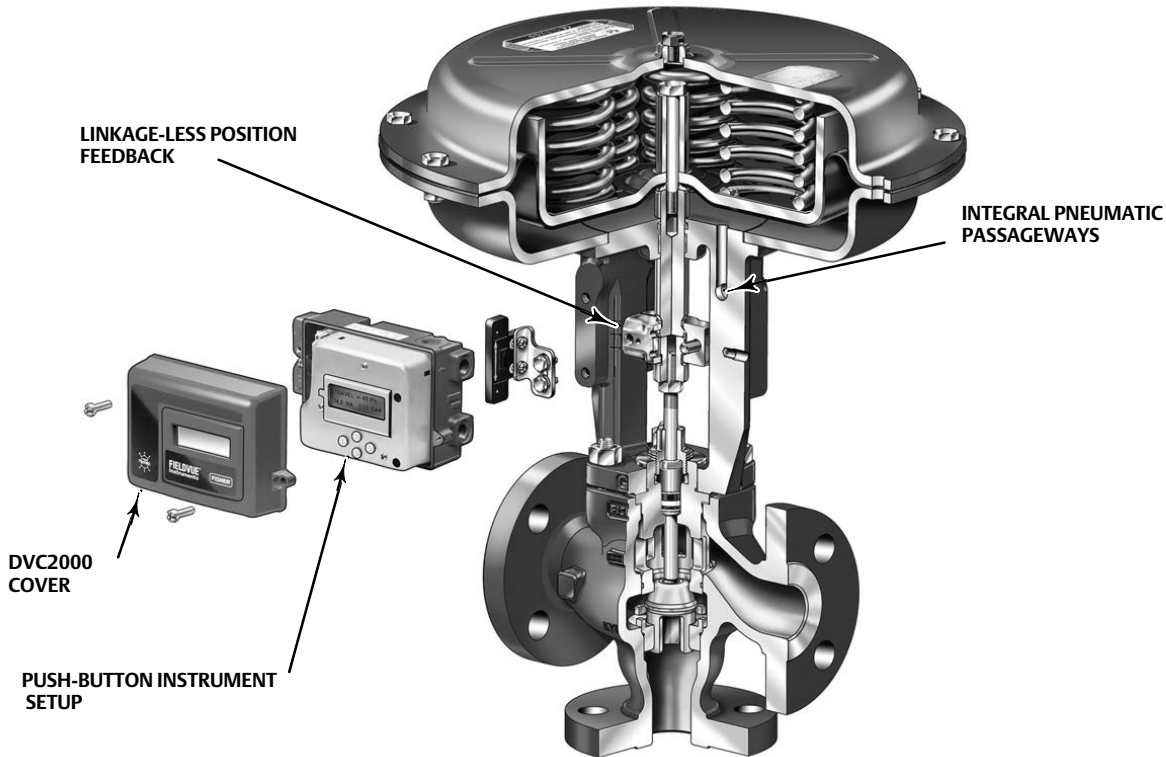

Optimized valve and actuator system. Product simplicity and ease of selection form the foundation of the GX 3-Way. Mounted with a digital or analog positioner, the GX 3-Way provides high performance control across a wide range of process applications.

Compact actuator design. The multi-spring GX 3-Way actuator is a compact robust design. The GX 3-Way design has been optimized to eliminate complicated 3-way actuator sizing procedures - once the valve body and port size are selected, the actuator size is fixed.

Reliable Actuator Performance. Special actuator diaphragm material helps reduce common problems such as air oxidation, thermal aging, low temperature embrittlement, and loss of retention (see table 6). The double-sided diaphragm within the actuator helps eliminate mechanical wear-induced failure.

Modular design. The design architecture has been optimized to maximize the use of common parts across sizes. The actuator stem and stem connector are used across all GX 3-Way sizes.

Low lifetime costs. Reduced product complexity, low parts count, and part commonality all contribute to reduced inventory and maintenance costs.

Stable flow control. The flow cavity of the GX 3-Way valve body has been engineered to provide stable flow and reduce process variability. This linear stability for both converging and diverging flow is perfectly suited for temperature and pH control applications.

Emission Requirements— ENVIRO-SEAL packing systems provide an improved stem seal to help prevent the loss of valuable or hazardous process fluid. The GX 3-Way comes standard with ENVIRO-SEAL PTFE packing. ENVIRO-SEAL graphite ULF packing is also available for all sizes and is standard on high temperature constructions.

Easy maintenance. The simple screwed seat-ring and one-piece plug and stem design provide easy maintenance. Design simplicity and parts commonality contribute to reduced spares inventory. The integrated DVC2000 and DVC6200 digital valve controllers allow easy instrument removal, without a

requirement for tubing disconnection or replacement (fail-down construction).

Digital valve controller. The GX 3-Way is available with the DVC2000 digital valve controller. The DVC2000 is easy to use, compact, and designed for easy mounting. It converts a 4-20 mA input signal into a pneumatic output signal, which feeds the control valve actuator. Instrument setup is performed with a push button and LCD interface. This interface is protected from the environment within a sealed enclosure. The interface supports multiple languages, including German, French, Italian, Spanish, Chinese, Japanese, Portuguese, Russian, Polish, Czech, Arabic, and English.

Intrinsic safety and non-incendive construction is available to CSA, FM, ATEX, and IEC standards. An optional module provides integrated limit switches and a position transmitter.

Integrated mounting. The DVC2000 and DVC6200 digital valve controllers integrally mount to the GX 3-Way actuator, eliminating the need for mounting brackets. The DVC2000 transmits a pneumatic signal

to the actuator casing via an air passage in the yoke leg, causing the valve to stroke (see figure 12). This eliminates the need for positioner-to-actuator tubing in the fail-down configuration.

The DVC2000 and DVC6200 mounting interfaces are identical on both sides of the actuator yoke for valve body sizes DN 25 through DN 100 (NPS 1 through 4). This symmetrical design allows the DVC2000 to be easily moved from one side of the valve to the other without the need to rotate the actuator.

Linkage-less feedback. The DVC2000 and DVC6200 digital valve controllers offer as standard a non-contacting valve position feedback system. This is a true linkage-less design, which uses no levers and no touching parts between the valve stem and the positioner.

Additional Accessory selection. The GX 3-Way is available with a variety of digital or analog positioners besides the DVC2000 or DVC6200, as well as solenoid and limit switches. The actuator is also compatible with the IEC 60534-6-1 (NAMUR) positioner mounting standard.

Flow Directions -- Side Port Common Constructions

Figure 4. Side Port Common Construction Details for Diverging Constructions

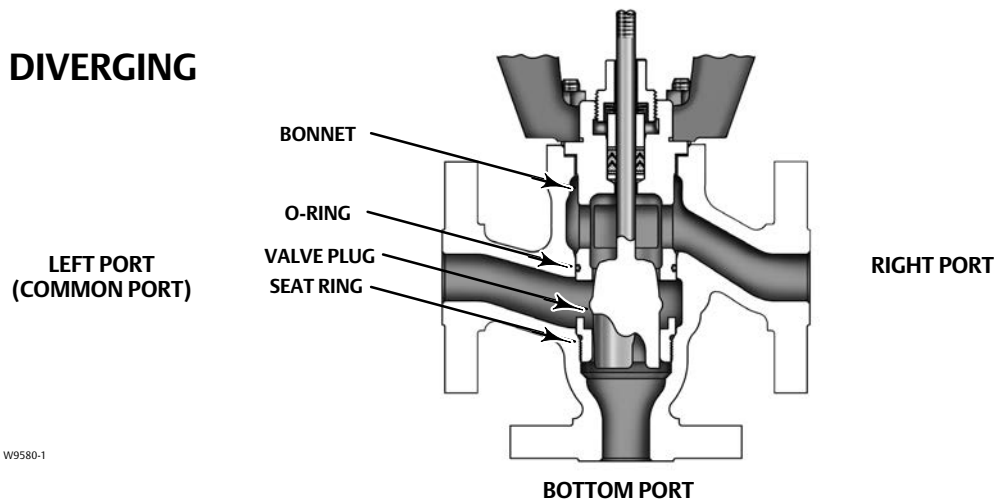

Figure 5. Fisher GX 3-Way Flow Directions for Side Port Common Diverging Constructions

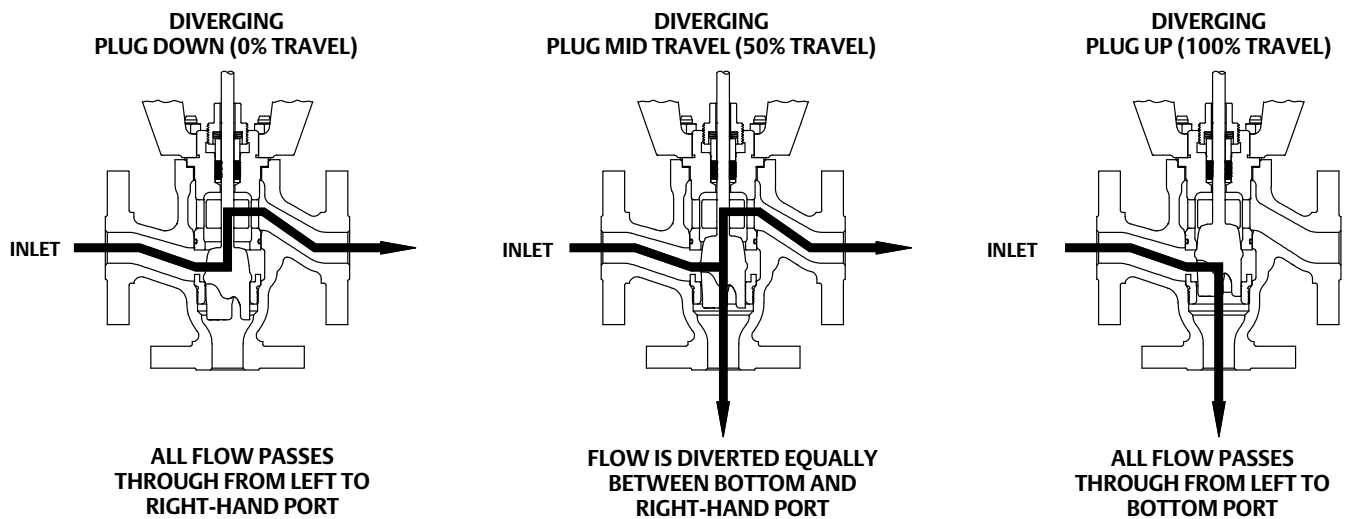
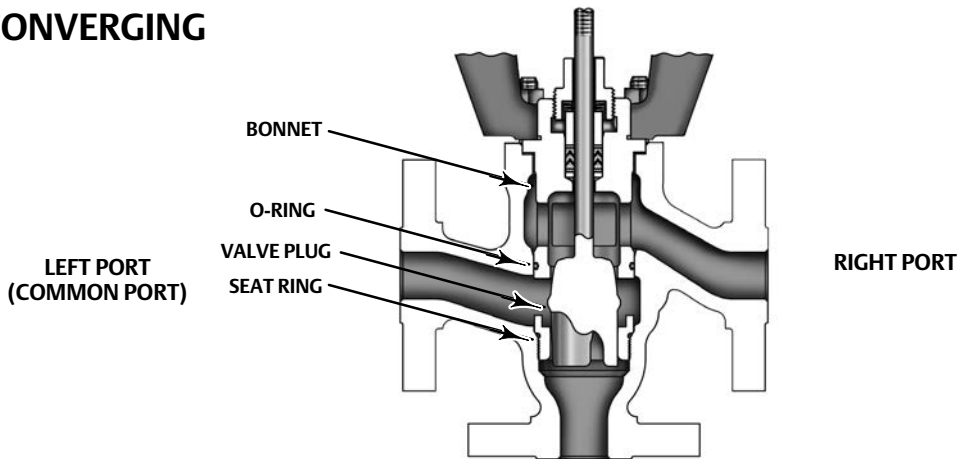

Figure 6. Side Port Common Construction Details for Converging Constructions

CONVERGING



W9580-1

Figure 7. Fisher GX 3-Way Flow Directions for Side Port Common Converging Constructions

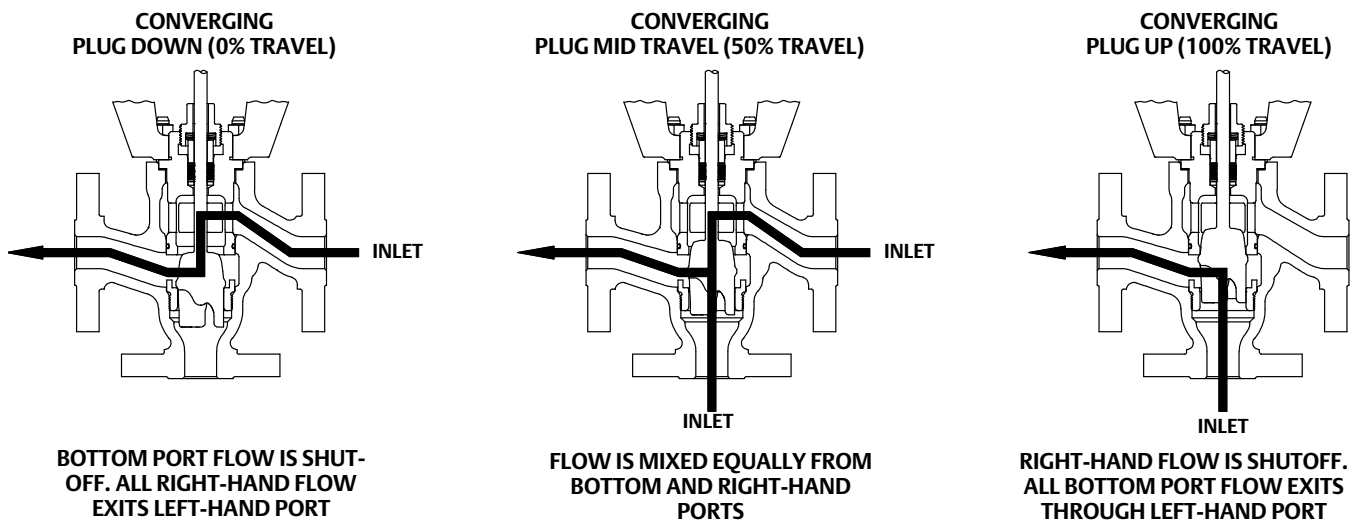

Flow Directions -- Bottom Port Common Constructions

Figure 8. Bottom Port Common Construction Details for Diverging Constructions

DIVERGING

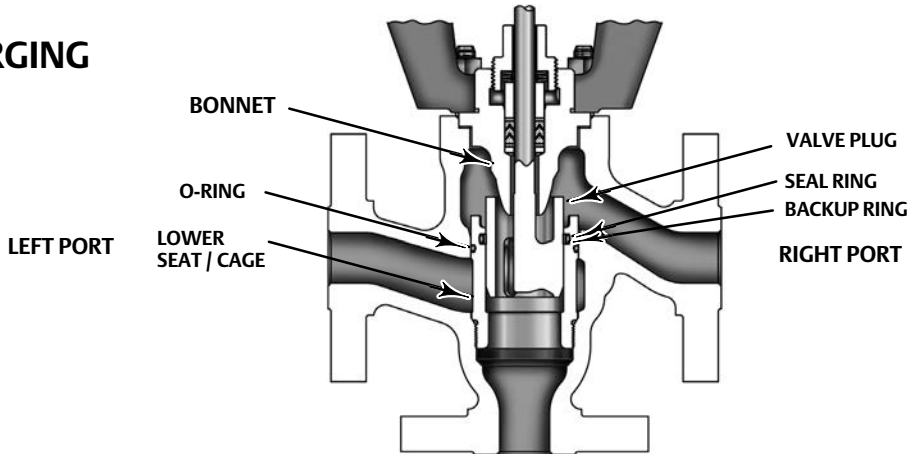

W9579-1

Figure 9. Fisher GX 3-Way Flow Directions for Bottom Port Common Diverging Constructions

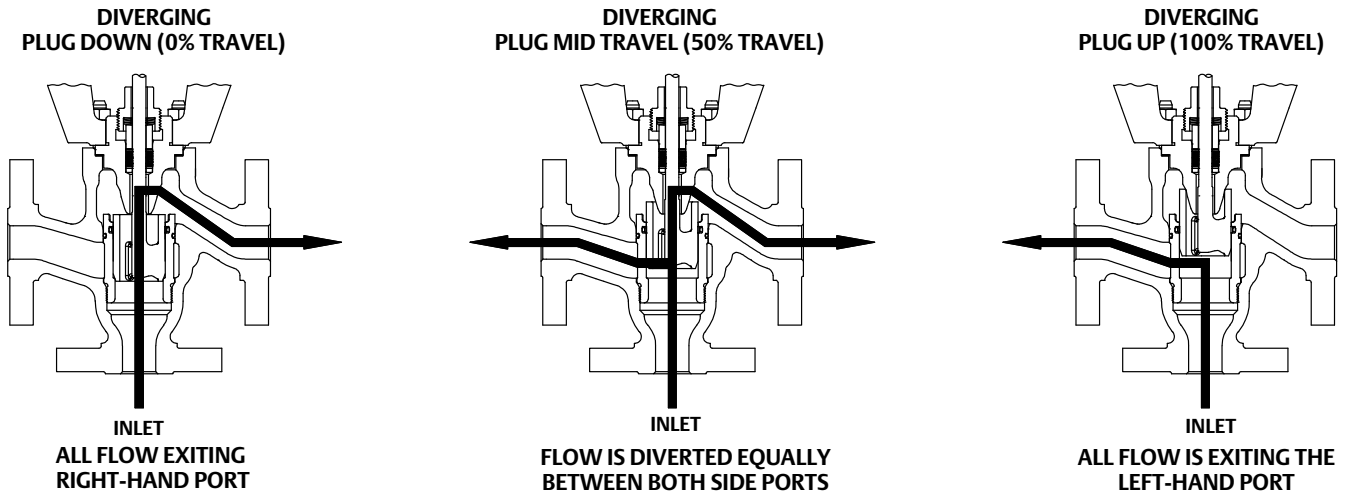
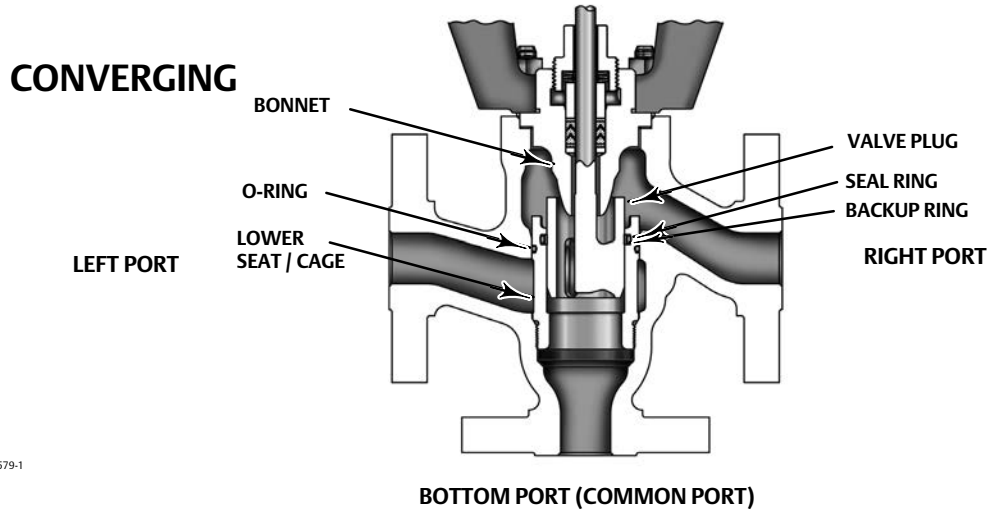
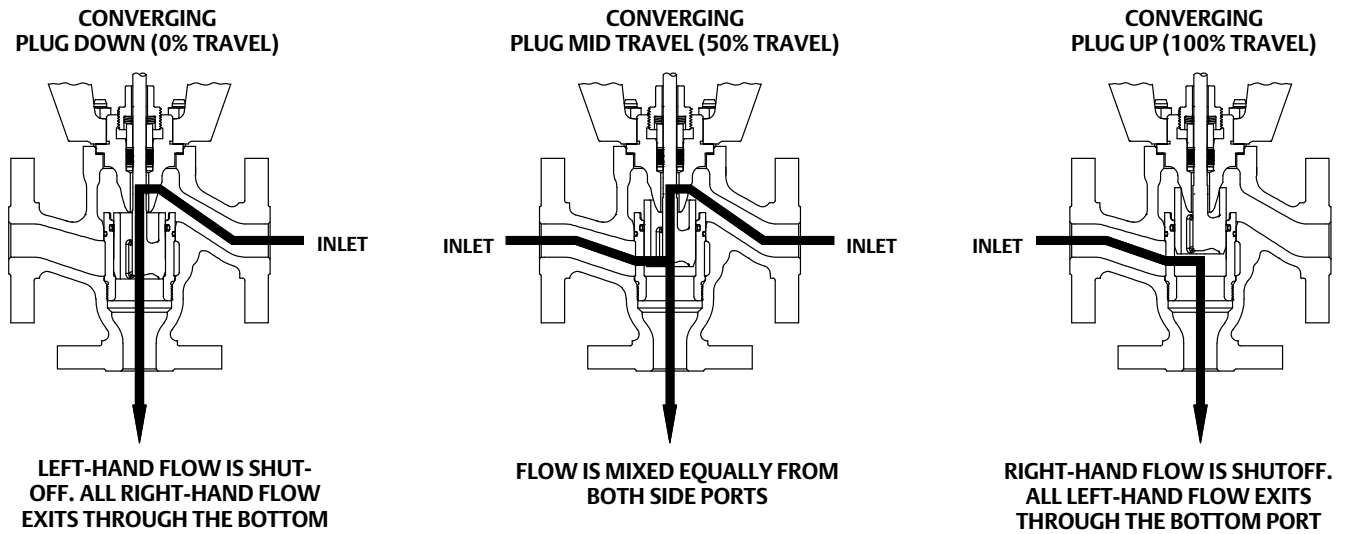

Figure 10. Bottom Port Common Construction Details for Converging Constructions



W9579-1

Figure 11. Fisher GX 3-Way Flow Directions for Bottom Port Common Converging Constructions



Principle of Operation - GX 3-Way Actuator

Figure 12. Fisher GX 3-Way Principle of Operation -- Actuator Fail Position

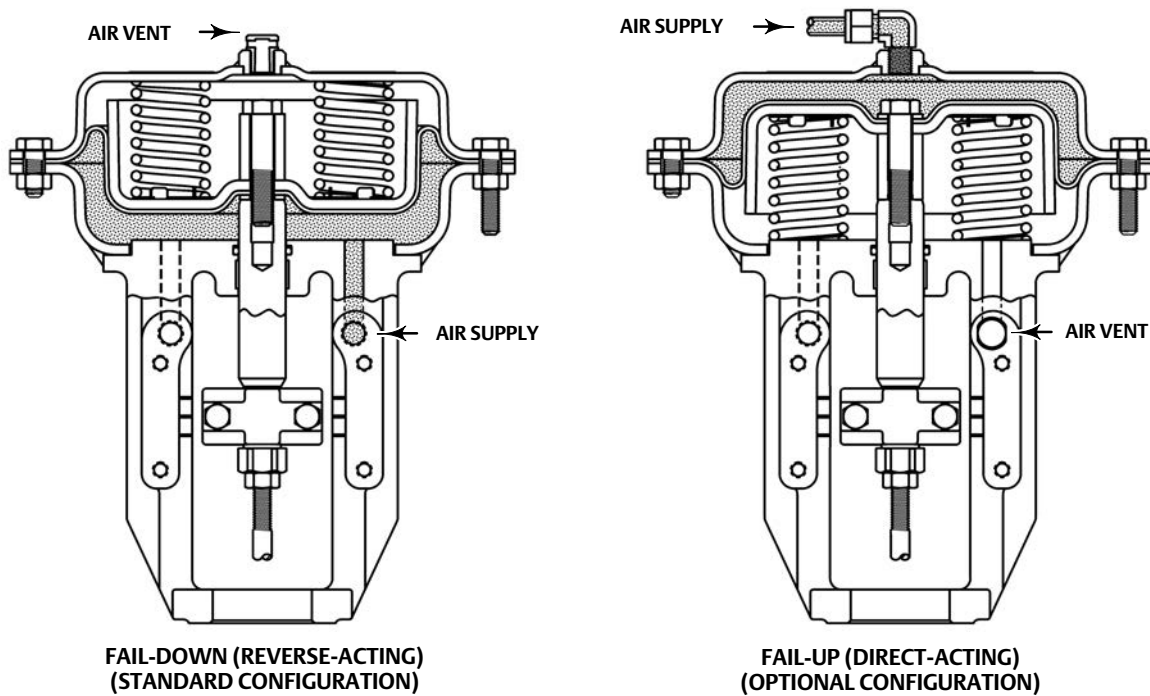

E0896-3

Integrated Air Supply. When mounted with the DVC2000 digital valve controller, the GX 3-Way uses an integrated actuator air supply system. In the fail-down configuration, air is supplied to the lower

actuator casing via a port on the actuator yoke face -- no tubing is required. In the fail-up configuration, air is supplied to the upper casing via tubing.

GX 3-Way Control Valve Specifications and Materials of Construction

Table 1. Fisher GX 3-Way Valve Specifications⁽¹⁾

Specifications	EN	ASME	
Valve Body Size	DN 25, 40, 50, 80, 100	NPS 1, 1-1/2, 2, 3, 4	
Pressure Rating	PN 10 / 16 / 25 / 40 per EN 1092-1	CL150 / 300 per ASME B16.34	
End Connections	Flanged raised face per EN 1092-1	Flanged raised face per ASME B16.5 Screwed (NPS 1, 1-1/2, and 2)	
Valve Body Materials	1.0619 steel	ASME SA216 WCC steel	
	1.4409 stainless steel	ASME SA351 CF3M stainless steel	
Bonnet Materials	1.4409 stainless steel / CoCr-A	SA351 CF3M SST / CoCr-A	
Face-to-Face Dimensions	See table 10		
Shutoff per IEC 60534-4 and ANSI/FCI 70-2	Metal seat - Class IV (standard) SPC High Temperature construction: Metal seat - Class IV for bottom seat, Class II for upper seat		
Flow Direction	Converging and Diverging		
Flow Coefficients	See Fisher Catalog 12		
Trim Style	Type	Plug Sizes	Description
	Side Port Common	All sizes	Unbalanced Port-guided
	Bottom Port Common	All sizes	Balanced Cage-guided

1. Stainless steel valve body is recommended for steam service when the high temperature construction is selected.

Table 2. Materials (Other Valve Components)

Component	Material
Packing Follower	S21800 SST screwed follower
Body/Bonnet Bolting and Nuts	SA193-B7 studs / SA194-2H nuts with NCF2 coating for carbon steel and stainless steel constructions
Packing	ENVIRO-SEAL Live-loaded PTFE V-ring (standard) with N07718 Belleville springs
	ENVIRO-SEAL Live-loaded Graphite ULF (optional) with N07718 Belleville springs, (standard) on High Temperature construction.
Bonnet Gasket	Graphite laminate
Bottom Port Common Trim (all sizes)	Carbon-Filled PTFE Seal Ring
	NBR (Standard) -46 to 82°C (-50 to 180°F)
	Ethylene Propylene [EPDM] (Optional): -46 to 232°C (-50 to 450°F) in steam and hot water; -46 to 121°C (-50 to 250°F) in air (EPDM is not recommended for use in hydrocarbons) FKM Fluorocarbon (Optional): -18 to 204°C (0 to 400°F) (Applicable in a wide variety of solvents, chemicals, and hydrocarbons. Avoid use with steam, ammonia, or hot water over 82°C [180°F])
O-ring (not used with GX 3-Way High Temperature)	NBR (Standard) -46 to 82°C (-50 to 180°F)
	Ethylene Propylene [EPDM] (Optional): -46 to 232°C (-50 to 450°F) in steam and hot water; -46 to 121°C (-50 to 250°F) in air (EPDM is not recommended for use in hydrocarbons)
	FKM Fluorocarbon (Optional): -18 to 204°C (0 to 400°F) (Applicable in a wide variety of solvents, chemicals, and hydrocarbons. Avoid use with steam, ammonia, or hot water over 82°C [180°F])
Seal Ring (GX 3-Way High Temperature)	Graphite (FMS 17F27) -46 to 371°C (-50 to 700°F)
Stem Extension (GX 3-Way High Temperature)	Stainless steel

Table 3. Trim Materials (all sizes)

Valve Body Construction	Trim Type	Stem	Plug	Upper Seat	Lower Seat/Cage ⁽¹⁾
Carbon steel (1.0619 / WCC)	Bottom Port Common	S31603 strain hardened	CF3M Chrome-plated	CF3M/CoCr-A	CF3M
	Side Port Common	S31603 strain hardened	CF3M	CF3M/CoCr-A	CF3M
Stainless steel (1.4409 / CF3M)	Bottom Port Common	S31603 strain hardened	CF3M Chrome-plated	CF3M/CoCr-A	CF3M
	Side Port Common	S31603 strain hardened	CF3M	CF3M/CoCr-A	CF3M

1. HT construction includes CF3M/CoCr-A lower seating. Seat and guide surfaces are hard-faced.

Table 4. Allowable Temperature Ranges for Valve Body, Bonnet and Trim⁽¹⁾

VALVE BODY / BONNET MATERIAL	BONNET STYLE	ENVIRO-SEAL PACKING	GASKET	TRIM STYLE	TEMPERATURE			
					°C		°F	
					Min	Max	Min	Max
1.0619/SA216 WCC Steel	Standard	PTFE or Graphite ULF	Graphite laminate	Bottom Port Common, Side Port Common	-29	232	-20	450
1.4409/SA351 CF3M SST	Standard	PTFE or Graphite ULF	Graphite laminate	Bottom Port Common, Side Port Common	-46	232	-50	450
1.0619/SA216 WCC Steel	HT Construction	Graphite ULF	Graphite laminate	Side Port Common	-29	371	-20	700
1.4409/SA351 CF3M SST	HT Construction	Graphite ULF	Graphite laminate	Side Port Common	-46	371	-50	700

1. Bonnet O-ring and back-up ring materials used on BPC trim may be limited by temperature and application.

Figure 13. Material Pressure/Temperature Curves

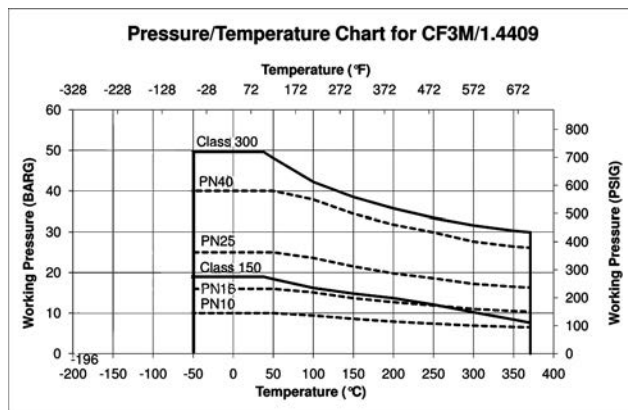
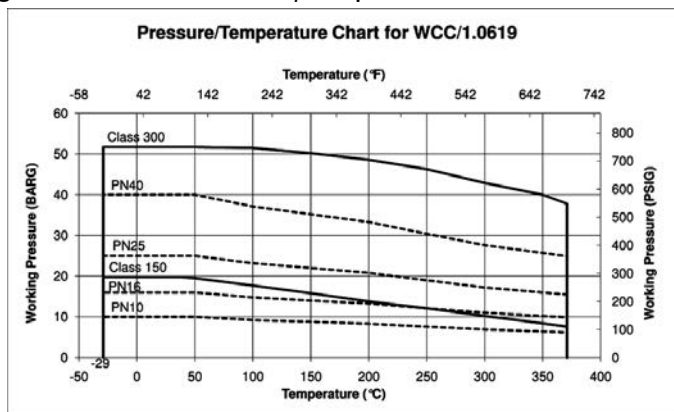
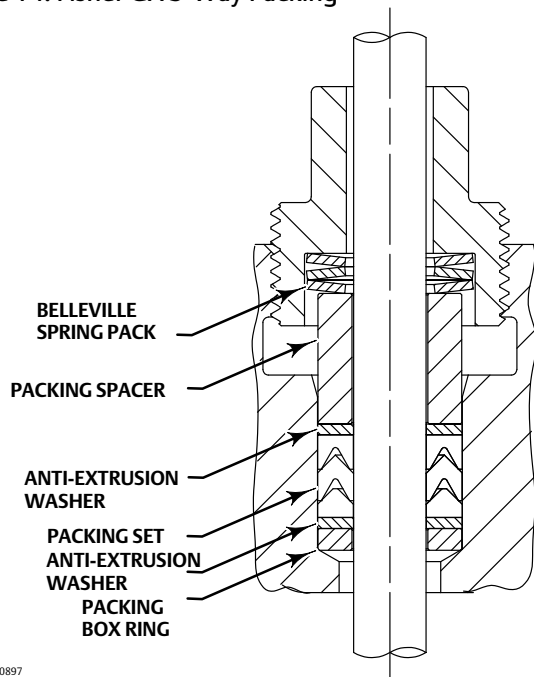
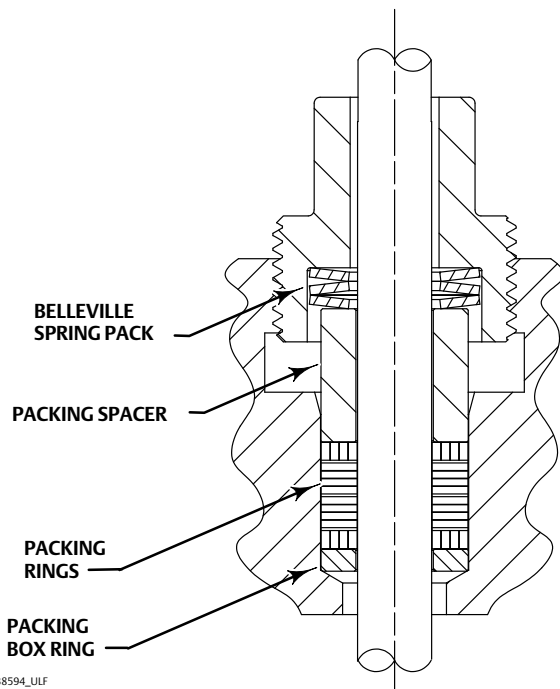

Figure 14. Fisher GX 3-Way Packing



E0897

**STANDARD BONNET WITH ENVIRO-SEAL LIVE-LOADED PTFE PACKING SET
DN 25 through DN 100 (NPS 1 through 4)**



GE38594_ULF

**STANDARD BONNET WITH OPTIONAL ENVIRO-SEAL LIVE-LOADED GRAPHITE ULF
PACKING SET (STANDARD ON HIGH TEMPERATURE CONSTRUCTION)
DN 25 through DN 100 (NPS 1 through 4)**

The GX 3-Way Diaphragm Actuator

Figure 15. Fisher GX 3-Way Actuator

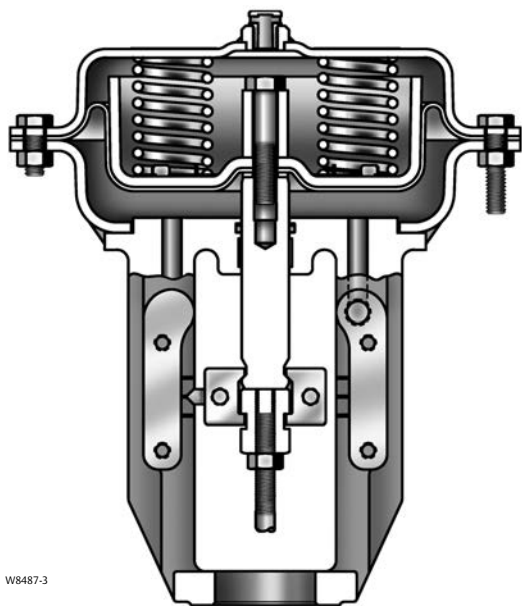

W8487-3

The GX 3-Way uses a multi-spring, pneumatic diaphragm actuator (see figure 15). It is capable of air supply pressures up to 5.0 barg (72 psig), allowing valve shutoff at high pressure drops (see table 8).

The GX 3-Way product selection system automatically matches the actuator to the valve, eliminating the need for complex actuator sizing procedures.

The multiple spring design provides the preload, eliminating the need for bench set adjustment. The actuator is available in fail-down and fail-up configurations.

The GX 3-Way actuator can be used for throttling or on-off service.

The GX 3-Way is available with the integrated DVC2000 digital valve controller. Other digital and analog positioners are available, as well as optional solenoids and limit switches.

Table 5. Actuator Specifications

Description	Pneumatic spring-return diaphragm actuator
Operating Principle	Fail-down (standard configuration) Fail-up (optional configuration)
Operating Pressure Ranges	See tables 8 and 9
Ambient Temperature	-46 to 82°C (-50 to 180°F)
Pressure Connection (Fail-Up Construction)	G 1/4 internal casing connection
Finish	Powder coat polyester

Table 6. Materials of Construction

Part	Material
Upper and Lower Casings	AISI 1010 stamped carbon steel
Springs	Steel
Diaphragm	NBR and nylon
Diaphragm Plate	AISI 1010 stamped carbon steel
Yoke and Yoke Extension on High Temperature Construction	Carbon steel
Casing Fasteners	A2-70 stainless steel bolts and nuts
Actuator Rod	Stainless steel
Stem Connector	CF3M
Stem Connector Fasteners	SA193-B7 bolts with NCF2 coating
Stem Bushing	High-density polyethylene (HDPE)
Stem Seal	NBR

Actuator Selection

With the GX 3-Way, actuator selection has never been easier. Once the valve size has been determined, the actuator is automatically selected.

The following tables provide the maximum allowable pressure drops for the GX 3-Way. See table 8 for Side Port Common construction and table 9 for Bottom Port Common construction. For optimal performance, the GX 3-Way should be operated with a FIELDVUE digital valve controller.

GX ISO 5210 Electric Actuator Mounting

Electric actuator mounting is available for any manufacturing models that comply with ISO 5210, Flange type F7. The mounting offering includes a GX yoke, actuator rod adaptor, spacer, and bolting.

Thrust limitations apply when sizing electric actuators (see table 7).

Mounting offering can be engineered if not already available for a selected actuator. For additional information, contact your [Emerson Process Management sales office](#).



**Table 7. Fisher GX 3-Way Maximum Allowable Thrust for use with ISO 5210 Electric Actuators
(THRUST LIMITATIONS APPLY IN BOTH TRAVEL DIRECTIONS)**

VALVE SIZE	STEM DIAMETER	TRAVEL	STEM MATERIAL	MAXIMUM THRUST	
	mm	mm		N	lbf
DN25-DN40 (NPS 1 to 1-1/2)	10	19	S31603	6900	1550
DN50 (NPS 2)	14	19	S31603	14000	3150
DN80-DN100 (NPS 3 to 4)	14	38	S31603	14000	3150

Table 8. Maximum Allowable Pressure Drop (Side Port Common)

VALVE SIZE	ACTUATOR SIZE	FLOW DIRECTION	ENVIRO-SEAL PACKING	FAIL-DOWN					FAIL-UP				
				Operating Pressure				MAX DP @ Maximum Supply Pressure	Operating Pressure				MAX DP @ Maximum Supply Pressure
				3 bar	3.44 bar	4 bar	5 bar		3 bar	3.44 bar	4 bar	5 bar	
DN25	225	Converging	PTFE	18.1	21.7	21.7	21.7	21.7 bar @ 5.0 bar	19.7	20.2	20.2	20.2	20.2 bar @ 5.0 bar
			ULF	12.2	16.2	16.2	16.2	16.2 bar @ 5.0 bar	14.2	14.3	14.3	14.3	14.3 bar @ 5.0 bar
		Diverging	PTFE	14.0	14.0	14.0	14.0	14.0 bar @ 5.0 bar	14.0	14.0	14.0	14.0	14.0 bar @ 5.0 bar
			ULF	14.0	14.0	14.0	14.0	14.0 bar @ 5.0 bar	14.0	14.0	14.0	14.0	14.0 bar @ 5.0 bar
DN40	225	Converging	PTFE	18.1	21.7	21.7	21.7	21.7 bar @ 5.0 bar	19.7	20.2	20.2	20.2	20.2 bar @ 5.0 bar
			ULF	12.2	16.2	16.2	16.2	16.2 bar @ 5.0 bar	14.2	14.3	14.3	14.3	14.3 bar @ 5.0 bar
		Diverging	PTFE	14.0	14.0	14.0	14.0	14.0 bar @ 5.0 bar	14.0	14.0	14.0	14.0	14.0 bar @ 5.0 bar
			ULF	14.0	14.0	14.0	14.0	14.0 bar @ 5.0 bar	14.0	14.0	14.0	14.0	14.0 bar @ 5.0 bar
DN50	750	Converging	PTFE	29.0	48.4	48.4	---	48.4 bar @ 4.0 bar	35.4	44.9	44.9	---	44.9 bar @ 4.0 bar
			ULF	25.8	45.5	45.5	---	45.5 bar @ 4.0 bar	32.6	41.7	41.7	---	41.7 bar @ 4.0 bar
		Diverging	PTFE	30.0	30.0	30.0	---	30.0 bar @ 4.0 bar	30.0	30.0	30.0	---	30.0 bar @ 4.0 bar
			ULF	30.0	30.0	30.0	---	30.0 bar @ 4.0 bar	30.0	30.0	30.0	---	30.0 bar @ 4.0 bar
DN80	750	Converging	PTFE	10.5	19.0	24.2	---	24.2 bar @ 4.0 bar	12.0	20.2	24.2	---	24.2 bar @ 4.0 bar
			ULF	9.2	17.7	23.0	---	23.0 bar @ 4.0 bar	10.7	19.0	22.9	---	22.9 bar @ 4.0 bar
		Diverging	PTFE	16.0	16.0	16.0	---	16.0 bar @ 4.0 bar	16.0	16.0	16.0	---	16.0 bar @ 4.0 bar
			ULF	16.0	16.0	16.0	---	16.0 bar @ 4.0 bar	16.0	16.0	16.0	---	16.0 bar @ 4.0 bar
DN100	750	Converging	PTFE	6.3	11.3	14.7	---	14.7 bar @ 4.0 bar	7.2	12.2	14.4	---	14.4 bar @ 4.0 bar
			ULF	5.5	10.5	13.9	---	13.9 bar @ 4.0 bar	6.5	11.5	13.6	---	13.6 bar @ 4.0 bar
		Diverging	PTFE	10.0	10.0	10.0	---	10.0 bar @ 4.0 bar	10.0	10.0	10.0	---	10.0 bar @ 4.0 bar
			ULF	10.0	10.0	10.0	---	10.0 bar @ 4.0 bar	10.0	10.0	10.0	---	10.0 bar @ 4.0 bar

Table 9. Maximum Allowable Pressure Drop (Bottom Port Common)

VALVE SIZE	ACTUATOR SIZE	FLOW DIRECTION	ENVIRO-SEAL PACKING	FAIL-DOWN					FAIL-UP				
				Operating Pressure				MAX DP @ Maximum Supply Pressure	Operating Pressure				MAX DP @ Maximum Supply Pressure
				3 bar	3.44 bar	4 bar	5 bar		3 bar	3.44 bar	4 bar	5 bar	
DN25	225	Converging	PTFE	32.4	50.1	51.7	51.7	51.7 bar @ 5.0 bar	36.2	36.2	36.2	36.2	36.2 bar @ 5.0 bar
			ULF	21.7	39.4	51.7	51.7	51.7 bar @ 5.0 bar	25.6	25.6	25.6	25.6	25.6 bar @ 5.0 bar
		Diverging	PTFE	28.0	28.0	28.0	28.0	28.0 bar @ 5.0 bar	28.0	28.0	28.0	28.0	28.0 bar @ 5.0 bar
			ULF	28.0	28.0	28.0	28.0	28.0 bar @ 5.0 bar	28.0	28.0	28.0	28.0	28.0 bar @ 5.0 bar
DN40	225	Converging	PTFE	25.0	38.7	51.7	51.7	51.7 bar @ 5.0 bar	27.9	27.9	27.9	27.9	27.9 bar @ 5.0 bar
			ULF	16.8	30.5	47.9	51.7	51.7 bar @ 5.0 bar	19.7	19.7	19.7	19.7	19.7 bar @ 5.0 bar
		Diverging	PTFE	22.0	22.0	22.0	22.0	22.0 bar @ 5.0 bar	22.0	22.0	22.0	22.0	22.0 bar @ 5.0 bar
			ULF	22.0	22.0	22.0	22.0	22.0 bar @ 5.0 bar	22.0	22.0	22.0	22.0	22.0 bar @ 5.0 bar
DN50	750	Converging	PTFE	35.2	51.7	51.7	---	51.7 bar @ 4.0 bar	51.7	51.7	51.7	---	51.7 bar @ 4.0 bar
			ULF	31.4	51.7	51.7	---	51.7 bar @ 4.0 bar	50.7	50.7	50.7	---	50.7 bar @ 4.0 bar
		Diverging	PTFE	30.0	30.0	30.0	---	30.0 bar @ 4.0 bar	30.0	30.0	30.0	---	30.0 bar @ 4.0 bar
			ULF	30.0	30.0	30.0	---	30.0 bar @ 4.0 bar	30.0	30.0	30.0	---	30.0 bar @ 4.0 bar
DN80	750	Converging	PTFE	19.5	35.2	51.7	---	51.7 bar @ 4.0 bar	45.0	45.0	45.0	---	45.0 bar @ 4.0 bar
			ULF	17.1	32.8	51.7	---	51.7 bar @ 4.0 bar	42.6	42.6	42.6	---	42.6 bar @ 4.0 bar
		Diverging	PTFE	25.0	25.0	25.0	---	25.0 bar @ 4.0 bar	25.0	25.0	25.0	---	25.0 bar @ 4.0 bar
			ULF	25.0	25.0	25.0	---	25.0 bar @ 4.0 bar	25.0	25.0	25.0	---	25.0 bar @ 4.0 bar
DN100	750	Converging	PTFE	19.5	35.2	51.7	---	51.7 bar @ 4.0 bar	45.0	45.0	45.0	---	45.0 bar @ 4.0 bar
			ULF	17.1	32.8	51.7	---	51.7 bar @ 4.0 bar	42.6	42.6	42.6	---	42.6 bar @ 4.0 bar
		Diverging	PTFE	25.0	25.0	25.0	---	25.0 bar @ 4.0 bar	25.0	25.0	25.0	---	25.0 bar @ 4.0 bar
			ULF	25.0	25.0	25.0	---	25.0 bar @ 4.0 bar	25.0	25.0	25.0	---	25.0 bar @ 4.0 bar

Valve-Actuator Dimensions and Weights

Table 10. Fisher GX 3-Way Dimensions and Weights (Standard and High Temperature Constructions)

VALVE SIZE	TYPE	PORT DIA		ACTUATOR SIZE	TRAVEL	A			B			C
		Upper	Lower			PN10 - PN40	CL150	CL300	PN10 - PN40	CL150	CL300	Bonnet
		mm	mm			mm	mm	mm	mm	mm	mm	mm
DN 25/ NPS 1	BPC	29	36	225	19	197	184	197	98.5	92	98.5	73
	SPC	36	36									
DN 40/ NPS 1-1/2	BPC	39	46	225	19	235	222	235	117.5	111	117.5	76
	SPC	36	36									
DN 50/ NPS 2	BPC	61	70	750	19	267	254	267	133.5	127	133.5	95
	SPC	46	46									
DN 80/ NPS 3	BPC	78	90	750	38	318	298	318	159	149	159	119
	SPC	70	70									
DN 100/ NPS 4	BPC	78	90	750	38	368	352	368	184	176	184	119
	SPC	90	90									

Table 11. Fisher GX 3-Way Dimensions and Weights

VALVE SIZE	D (Actuator Height)		E	F (AR)	TOTAL WEIGHT	
	Std Construction	High Temperature Construction	Casing Dia	Removal Height ⁽¹⁾	Std Construction	High Temperature Construction
	mm	mm	mm	mm	kg	kg
DN 25/ NPS 1	313	418	270	115	26	30
DN 40/ NPS 1-1/2	313	422	270	115	28	32
DN 50/ NPS 2	342	485	430	120	66	74
DN 80/ NPS 3	395	585	430	145	97	112
DN 100/ NPS 4	395	585	430	145	123	138

1. Clearance required for removing actuator from installed valve body.

Figure 16. Fisher GX 3-Way Dimensions (also see tables 10 and 11)

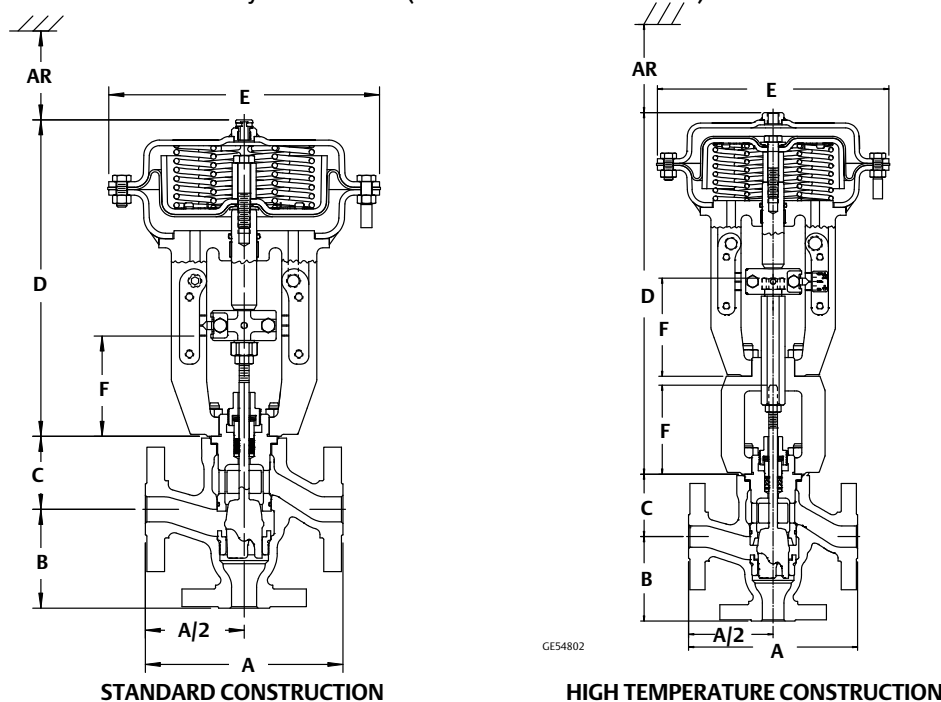
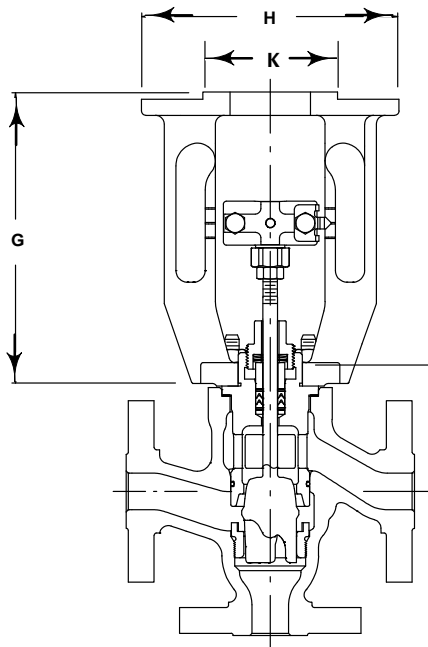

Table 12. Fisher GX 3-Way Electric Actuator Mounting Dimensions and Weights

VALVE SIZE	G	H	K	TOTAL WEIGHT, GX ELECTRIC ACTUATOR MOUNTING ASSEMBLY	
	ISO 5210 Electric Actuator Yoke Height	Yoke Diameter		Std Construction	High Temperature Construction
	mm	mm		kg	kg
DN 25/ NPS 1	202	170	92	17	21
DN 40/ NPS 1-1/2	202	170	92	19	23
DN 50/ NPS 2	202	170	92	29	37
DN 80/ NPS 3	222	170	92	57	72
DN 100/ NPS 4	226	170	92	83	98

Figure 17. Fisher GX 3-Way Electric Actuator Mounting Dimensions (also see table 12)



GE54756_2

Table 13. Positioner Selection Guidelines

Type	Digital I/P ⁽¹⁾	I/P ⁽²⁾	P/P ⁽³⁾	Intrinsic Safety ⁽⁴⁾	Flameproof / Explosion Proof ⁽⁴⁾	Non- Incendive ⁽⁴⁾
DVC2000	X			X		X
DVC6200	X			X	X	X
3661		X		X		X
3660			X			

1. Digital I/P - microprocessor based electro-pneumatic with HART communication.
 2. I/P - electro-pneumatic
 3. P/P - pneumatic
 4. Refer to [Fisher bulletin 9.2:001 \(D103222X012\)](#) for instrument hazardous area classification details.

GX 3-Way Actuator Accessories

The GX 3-Way is available with a variety of pneumatic (P/P), electro-pneumatic (I/P), and digital valve positioners, as well as limit switches and solenoids. Table 13 provides the basic features of the positioners offered with the GX 3-Way actuator.

The FIELDVUE DVC2000 Digital Valve Controller

The DVC2000 digital valve controller (figure 18) is simple to use, compact, and designed for the GX 3-Way control valve. It converts a 4-20mA input signal into a pneumatic output signal, which feeds the control valve actuator. Instrument setup is performed with a pushbutton and LCD interface. This interface is protected from the environment within an IP66 enclosure. Multiple languages are supported with the local interface including German, French, Italian, Spanish, Chinese, Japanese, Portuguese, Russian, Polish, Czech, Arabic, and English. Additionally, HART® communication is supported over the 4-20mA loop wiring.

The DVC2000 is designed to be integrally mounted to the GX 3-Way actuator, avoiding the need for mounting brackets. The DVC2000 mounts directly to an interface pad on the actuator yoke leg with a secure 3-point mounting. An internal passage inside the yoke leg transmits the pneumatic signal to the actuator casing, eliminating the need for external tubing (in the fail-down configuration).

Figure 18. FIELDVUE DVC2000 Digital Valve Controller



The high-performance linkage-less position feedback system eliminates physical contact between the valve stem and the digital valve controller or instrument. There are no wearing parts so cycle life is maximized. Additionally, the elimination of levers and linkages reduces the number of mounting parts and the mounting complexity. Digital valve controller or instrument replacement and maintenance is simplified because the feedback parts stay connected to the actuator.

The DVC2000 is available with an optional module which includes two (2) integral limit switches and a stem position transmitter. The limit switches are configurable for open and closed valve indication. The position transmitter provides a 4-20mA signal for valve position feedback verification. As an integral component to the instrument, this option module avoids the need for difficult-to-mount external switches and transmitters.

Designed to meet intrinsic safety and non-incendive requirements, this instrument delivers scalable functionality and high performance in a small package.

Optional Positioners and Instruments

3660 and 3661 Valve Positioners

The 3660 pneumatic and 3661 electro-pneumatic positioners are rugged, accurate, and feature low steady-state air consumption. Designed to meet intrinsic safety requirements, these positioners offer simple functionality in a small package. (See table 13.)

Figure 19. FIELDVUE DVC6200
Digital Valve Controller



W9713

DVC6200 Digital Valve Controller

The DVC6200 digital valve controller is a communicating, microprocessor-based current-to-pneumatic instrument. Using HART or FOUNDATION™ fieldbus communication protocol, access to critical instrument, valve, and process conditions is provided. When used with ValveLink™ software, valve diagnostic tests can be run while the valve is in service to advise you of the performance of the entire control valve assembly. Designed to meet a broad range of hazardous area classifications, this instrument offers maximum functionality to improve your process performance. (See figure 19 and table 13.)

Neither Emerson, Emerson Process Management, nor any of their affiliated entities assumes responsibility for the selection, use or maintenance of any product. Responsibility for proper selection, use, and maintenance of any product remains solely with the purchaser and end user.

Fisher, FIELDVUE, ENVIRO-SEAL, and ValveLink are marks owned by one of the companies in the Emerson Process Management business unit of Emerson Electric Co. Emerson Process Management, Emerson, and the Emerson logo are trademarks and service marks of Emerson Electric Co. All other marks are the property of their respective owners.

The contents of this publication are presented for informational purposes only, and while every effort has been made to ensure their accuracy, they are not to be construed as warranties or guarantees, express or implied, regarding the products or services described herein or their use or applicability. All sales are governed by our terms and conditions, which are available upon request. We reserve the right to modify or improve the designs or specifications of such products at any time without notice.

Emerson Process Management
Marshalltown, Iowa 50158 USA
Sorocaba, 18087 Brazil
Chatham, Kent ME4 4QZ UK
Dubai, United Arab Emirates
Singapore 128461 Singapore

www.Fisher.com