

# ENDURANCE™ General Purpose Conductivity Sensors

- INITIAL CALIBRATION NOT REQUIRED.  
Factory-measured cell constant ensures out-of-the-box accuracy.
- VERSATILE MOUNTING CONFIGURATIONS:  
screw-in, retractable, and flow-through.
- AVAILABLE WITH VARIOPOL (VP) quick disconnect fitting.

## APPLICATIONS

The Model 400/400VP, 402/402VP, and 404 sensors are intended for the determination of electrolytic conductivity in applications ranging from high purity water to clean cooling water. The sensors are ideal for use in clean, non-corrosive liquid having conductivity less than about 20,000  $\mu\text{S}/\text{cm}$ . For dirty or corrosive samples or for samples having high conductivity, a toroidal sensor such as the Model 228 or 226 is recommended.

## FEATURES

ENDURANCE sensors are metal electrode contacting conductivity sensors. They are available in cell constants of 0.01, 0.1, and 1.0/cm. The choice of cell constant depends on conductivity. High conductivity samples require larger cell constants. Consult the analyzer Product Data Sheet for recommended ranges and accuracy.

The sensors have concentric titanium electrodes separated by a PEEK insulator. EPDM O-rings seal the internal parts of the sensor from the process liquid.

Electrolytic conductivity is a strong function of temperature, and conductivity readings are typically converted to the value at a reference temperature. To measure temperature, ENDURANCE sensors use a platinum RTD located inside the inner electrode.



MODEL 400

MODEL 400VP



MODEL 402

(with insertion assembly)

MODEL 402VP



MODEL 404

**Model 400 sensors** are designed for direct screw-in insertion into process piping using a 3/4-inch MNPT fitting. The 400 sensor can also be used in sidestream samples. A 1-inch pipe tee with a 3/4-inch bushing is a suitable flow cell. A 3/4-inch pipe tee can be used with 0.1 and 1.0/cm cells. A transparent plastic flow cell is also available (PN 24091-02).

**Model 402 sensors** are retractable; they can be removed from the process piping without shutting down and draining the line. Maximum retraction pressure is 64 psig (542 kPa abs). The sensor fits through a 1-1/4 inch full-port ball valve. Order the retraction assembly, which includes the ball valve, pipe nipple, and packing adapter, as an option.

**Model 404 sensors** combine the conductivity sensor with a flow cell. The design has a small holdup volume, so response to sudden changes in process conductivity and temperature is rapid. Model 404 sensors are available with a PVC or stainless steel body. The stainless steel version can be disassembled for cleaning. The PVC version cannot be taken apart.

**Models 400 and 402 sensors** are available with Variopol 6 quick disconnect watertight connectors. Wire the interconnecting cable to the analyzer and run the cable to the sensor. The sensor plugs into the cable receptacle. To replace the sensor, simply disconnect the Variopol fitting and plug in a new sensor. There is no need to rewire or rerun cable.

---

## SPECIFICATIONS (Models 400 and 400VP)

**Cell constants:** 0.01, 0.1, and 1.0/cm

**Wetted materials:**

Electrodes: titanium  
Body: 316 stainless steel  
Insulator: PEEK  
O-rings: EPDM

**Process connection:** 3/4 inch MNPT

**Temperature:** 32 – 221°F (0 – 105°C)

**Temperature (option -60):** 32 – 392°F (0 – 200°C)

**Pressure:** 250 psig (1825 kPa abs) maximum

**Vacuum:** At 1.6 in. Hg (5.2 kPa) air leakage is less than 0.005 SCFM (0.00014 m<sup>3</sup>/min).

**Cable length (Model 400 only):** 10 ft (3.1 m) standard; 50 ft (15.2 m) optional

## SPECIFICATIONS (Models 402 and 402VP)

**Cell constants:** 0.01, 0.1, and 1.0/cm

**Wetted materials:**

Electrodes: titanium  
Sensor tube: 316 stainless steel  
Insulator: PEEK  
O-rings: EPDM  
Washer: Neoprene

**Process connection:** sensor is inserted through 1-1/4 inch NPT full port ball valve

**Temperature:** 32 – 212°F (0 – 100°C)

**Pressure:** 200 psig (1481 kPa abs) maximum

**Retraction pressure:** 64 psig (542 kPa abs) maximum

**Vacuum:** At 1.6 in. Hg (5.2 kPa) air leakage is less than 0.005 SCFM (0.00014 m<sup>3</sup>/min).

**Cable length (Model 402 only):** 10 ft (3.1 m).

For longer cable length, choose option -60 (integral junction box) and order interconnecting cable separately.

## SPECIFICATIONS (Model 404)

**Cell constants:** 0.01 and 0.1/cm

**Wetted materials (option -16):**

Electrodes: titanium  
Insulator: PEEK  
O-rings: EPDM  
Body: PVC  
Fittings: polyethylene

**Wetted materials (option -17):**

Electrodes: titanium  
Insulator: PEEK  
O-rings: EPDM  
Body: 303 stainless steel  
Fittings: 316 stainless steel

**Process connection (option -16):** 3/8 inch barbed tubing connector

**Process connection (option -17):** compression fitting for 3/8 inch OD tubing. Fittings can be removed to leave 1/4-inch FNPT ports.

**Temperature (option -16):** 32 – 140°F (0 – 60°C).

**Temperature (option -17):** 32 – 212°F (0 – 100°C).

**Pressure (option -16):** 100 psig (791 kPa abs) at 77°F (25°C); 20 psig (239 kPa abs) at 140°F (60°C)

**Pressure (option -17):** 100 psig (791 kPa abs) maximum

**Cable length:** 10 ft (3.1 m) standard; 50 ft (15.2 m) optional

## SPECIFICATIONS (Flow cell for Model 400/400VP, PN 24091-02)

### Wetted Materials:

Body: polycarbonate, polyester  
 Fittings: 316 stainless steel  
 O-ring: silicone

**Process connection:** compression fitting for 1/4 inch OD tubing

**Temperature:** 158°F (70°C) maximum

**Pressure:** 90 psig (722 kPa abs) maximum

## SPECIFICATIONS (Retraction assembly for Model 402/402VP, PN 23765-00)

**Assembly includes:** ball valve, retraction body and pipe nipple.

### Wetted Materials:

Ball valve: 316 stainless steel with Teflon<sup>1</sup> seals and seat steel  
 Nipple: 316 stainless steel  
 Packing rings: graphite  
 Packing bushing: 303 stainless steel  
 Retraction body: 316 stainless steel

**Process connection:** ball valve 1-1/4 inch FNPT; nipple 1-1/4 inch MNPT

**Temperature:** 32 – 212°F (0 – 100°C).

**Pressure:** 200 psig (1481 kPa abs) maximum

**Retraction pressure:** 64 psig (542 kPa abs) maximum

**Vacuum:** At 1.6 in. Hg (5.2 kPa) air leakage is less than 0.005 SCFM (0.00014 m<sup>3</sup>/min).

<sup>1</sup>Teflon is a registered trademark of E.I. duPont de Nemours and Co.

## INSTRUMENT COMPATIBILITY

ENDURANCE sensors are compatible with the 1056, 56, 5081-C, 6081-C, and 1066-C instruments. Consult the analyzer data sheet for the recommended conductivity range for each cell constant and the expected linearity over the range. For compatibility with older instruments, call the factory.

## WEIGHTS AND SHIPPING WEIGHTS (rounded up to the nearest 1 lb or 0.5 kg)

MODEL	WITH 10 ft. (3.1 m) CABLE		WITH 50 ft. CABLE		WITH JUNCTION BOX	
	Weight	Shipping Weight	Weight	Shipping Weight	Weight	Shipping Weight
400	1 lb (0.5 kg)	2 lb (1.0 kg)	4 lb (2.0 kg)	5 lb (2.5 kg)	3 lb (1.5 kg)	4 lb (2.0 kg)
402	3 lb (1.5 kg)	4 lb (2.0 kg)	--	--	4 lb (2.0 kg)	5 lb (2.5 kg)
404-16	2 lb (1.0 kg)	3 lb (1.5 kg)	4 lb (2.0 kg)	5 lb (2.5 kg)	--	--
404-17	4 lb (2.0 kg)	5 lb (2.5 kg)	6 lb (3.0 kg)	7 lb (3.5 kg)	--	--

MODEL	Weight	Shipping Weight
400VP	1 lb (0.5 kg)	2 lb (1.0 kg)
402VP	3 lb (1.5 kg)	4 lb (2.0 kg)

# SENSOR DIMENSIONS

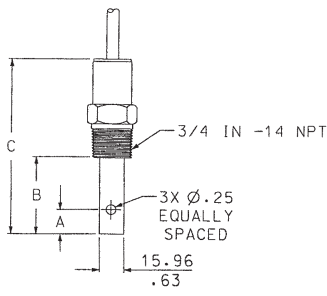

MODEL NO	A		B		C	
	INCHES	mm	INCHES	mm	INCHES	mm
400-11	1.59	40.39	1.98	50.34	4.52	114.8
400-12	.687	17.45	1.11	28.15	3.65	92.71
400-13	.667	16.94	1.13	28.70	3.67	93.22
400-11-36	1.59	40.39	5.49	139.4	8.00	203.2
400-12-36	.687	17.45	5.49	139.4	8.00	203.2
400-13-36	.667	16.94	5.49	139.4	8.00	203.2

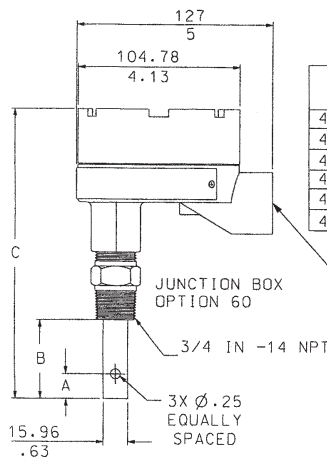

MODEL 400 SENSORS WITH JUNCTION BOX

MODEL NO	A		B		C	
	INCHES	mm	INCHES	mm	INCHES	mm
400-11-60	1.59	40.39	1.98	50.34	7.41	188.2
400-12-60	.687	17.45	1.11	28.15	6.49	164.9
400-13-60	.667	16.94	1.13	28.70	6.51	165.4
400-11-36-60	1.59	40.39	5.49	139.4	10.90	276.9
400-12-36-60	.687	17.45	5.49	139.4	10.90	276.9
400-13-36-60	.667	16.94	5.49	139.4	10.90	276.9

**Model 400 Dimensions**

# SENSOR DIMENSIONS

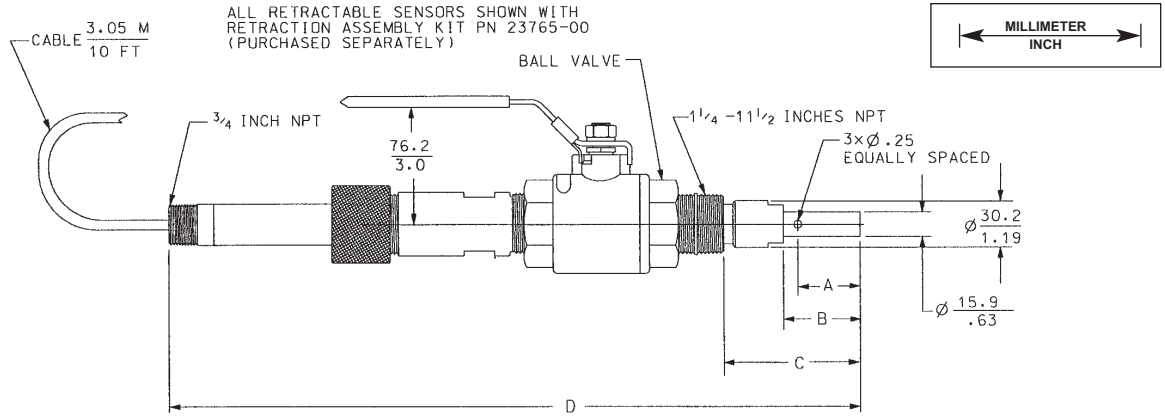

MODEL	RETRACTION ASSY KIT	A		B		C (MIN - MAX)		D	
		INCHES	mm	INCHES	mm	INCHES	mm	INCHES	mm
402-11	23765-00	1.59	40.4	1.98	50.3	3.21-5.34	82-136	18.13	460.5
402-12	23765-00	.687	17.4	1.11	28.2	2.34-4.47	59-114	17.33	440.2
402-13	23765-00	.667	16.9	1.13	28.7	2.36-4.49	60-114	17.33	440.2

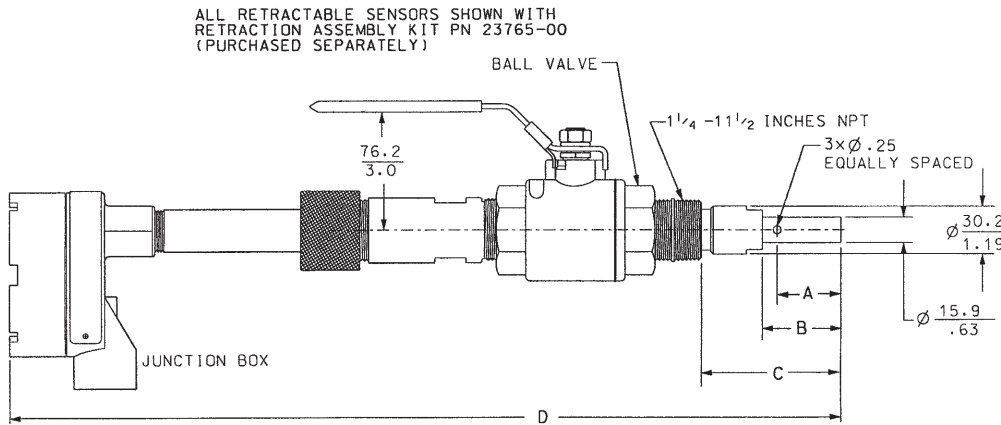

MODEL	RETRACTION ASSY KIT	A		B		C (MIN - MAX)		D	
		INCHES	mm	INCHES	mm	INCHES	mm	INCHES	mm
402-11	23765-00	1.59	40.4	1.98	50.3	3.21-5.34	82-136	21.1	537
402-12	23765-00	.687	17.4	1.11	28.2	2.34-4.47	59-114	20.3	515
402-13	23765-00	.667	16.9	1.13	28.7	2.36-4.49	60-114	20.3	515

**Model 402 Dimensions Shown with Options -31, and -60**

# SENSOR DIMENSIONS

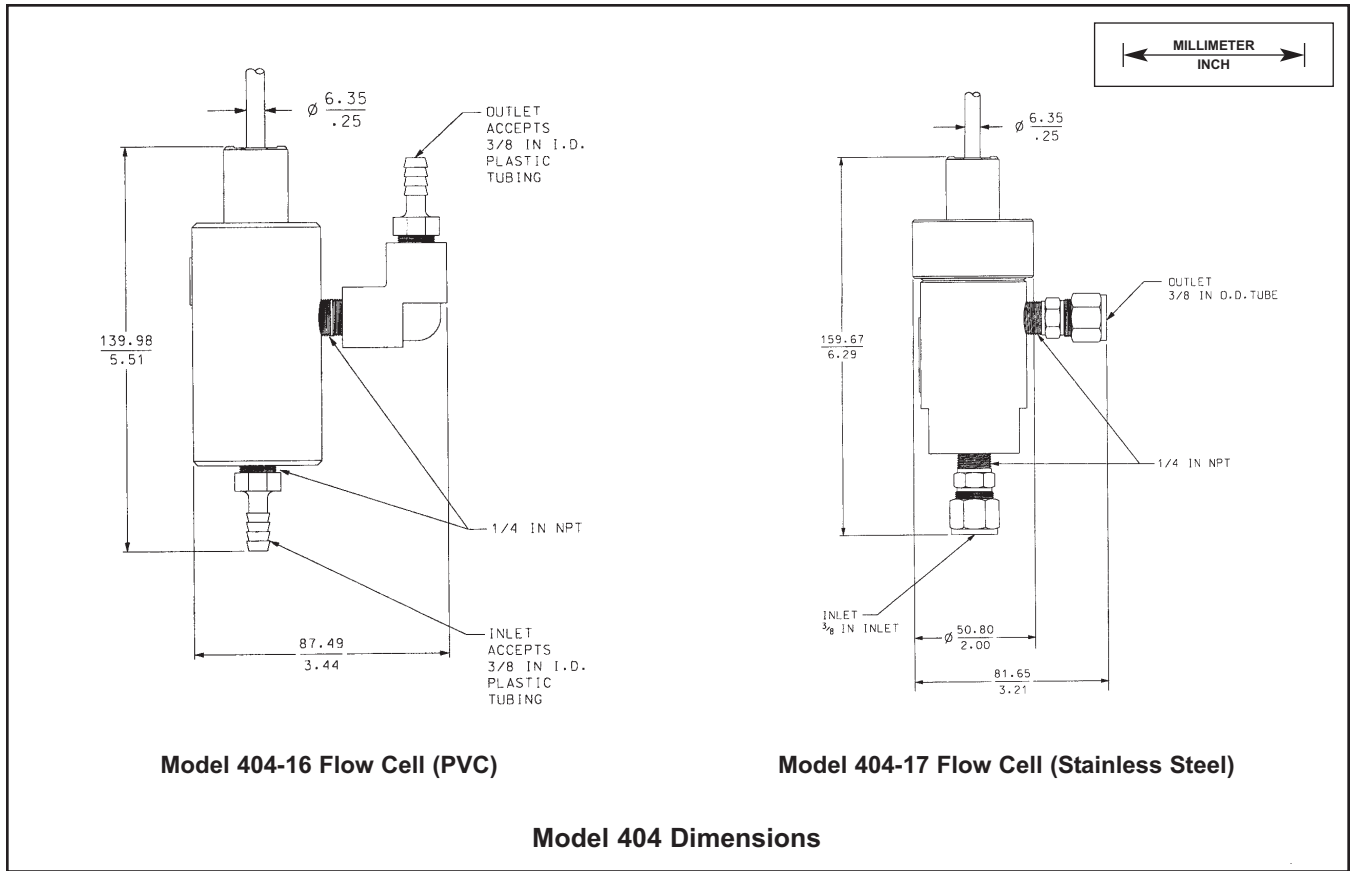

## SENSOR DIMENSIONS

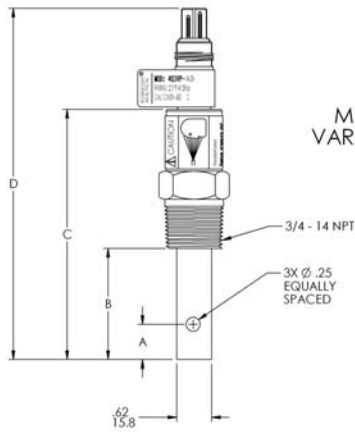

MODEL 400VP SENSOR WITH VARIOPOL (VP 6) CONNECTOR

MODEL NO	A		B		C		D	
	INCHES	mm	INCHES	mm	INCHES	mm	INCHES	mm
400VP-11	1.59	40.4	1.98	50.3	4.43	112.5	6.30	160.0
400VP-12	0.67	17.0	1.10	27.9	3.47	90.4	5.43	137.9
400VP-13	0.67	17.0	1.10	27.9	3.58	90.9	5.45	138.4
400VP-11-36	1.59	40.4	5.48	139.2	7.91	200.9	9.78	248.4
400VP-12-36	0.67	17.0	5.48	139.2	7.91	200.9	9.78	248.4
400VP-13-36	0.67	17.0	5.48	139.2	7.91	200.9	9.78	248.4

**Model 400VP Dimensions**

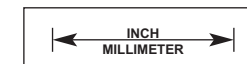
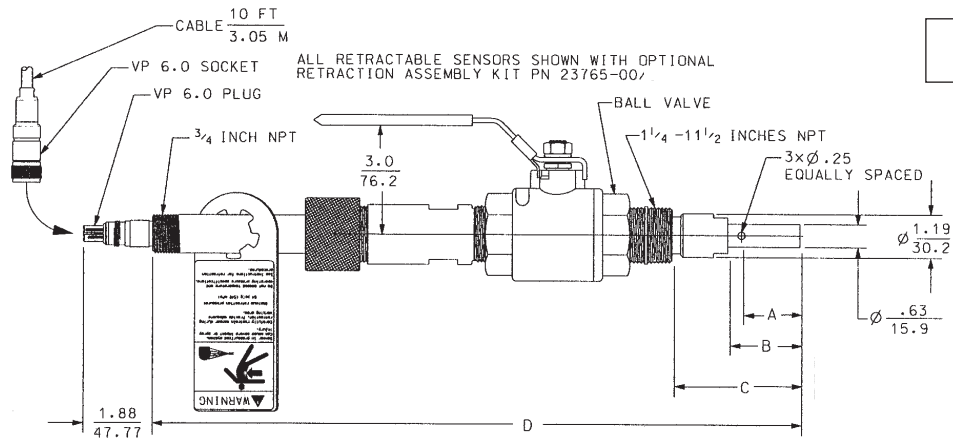

ALL RETRACTABLE SENSORS SHOWN WITH OPTIONAL RETRACTION ASSEMBLY KIT PN 23765-00/

MODEL	RETRACTION ASSY KIT	A		B		C (MIN - MAX)		D	
		INCHES	mm	INCHES	mm	INCHES	mm	INCHES	mm
402-11	23765-00	1.59	40.4	1.98	50.3	3.21-5.34	82-136	18.13	460.5
402-12	23765-00	.687	17.4	1.11	28.2	2.34-4.47	59-114	17.33	440.2
402-13	23765-00	.667	16.9	1.13	28.7	2.36-4.49	60-114	17.33	440.2

**Model 402VP Dimensions**

# INSTALLATION DETAILS

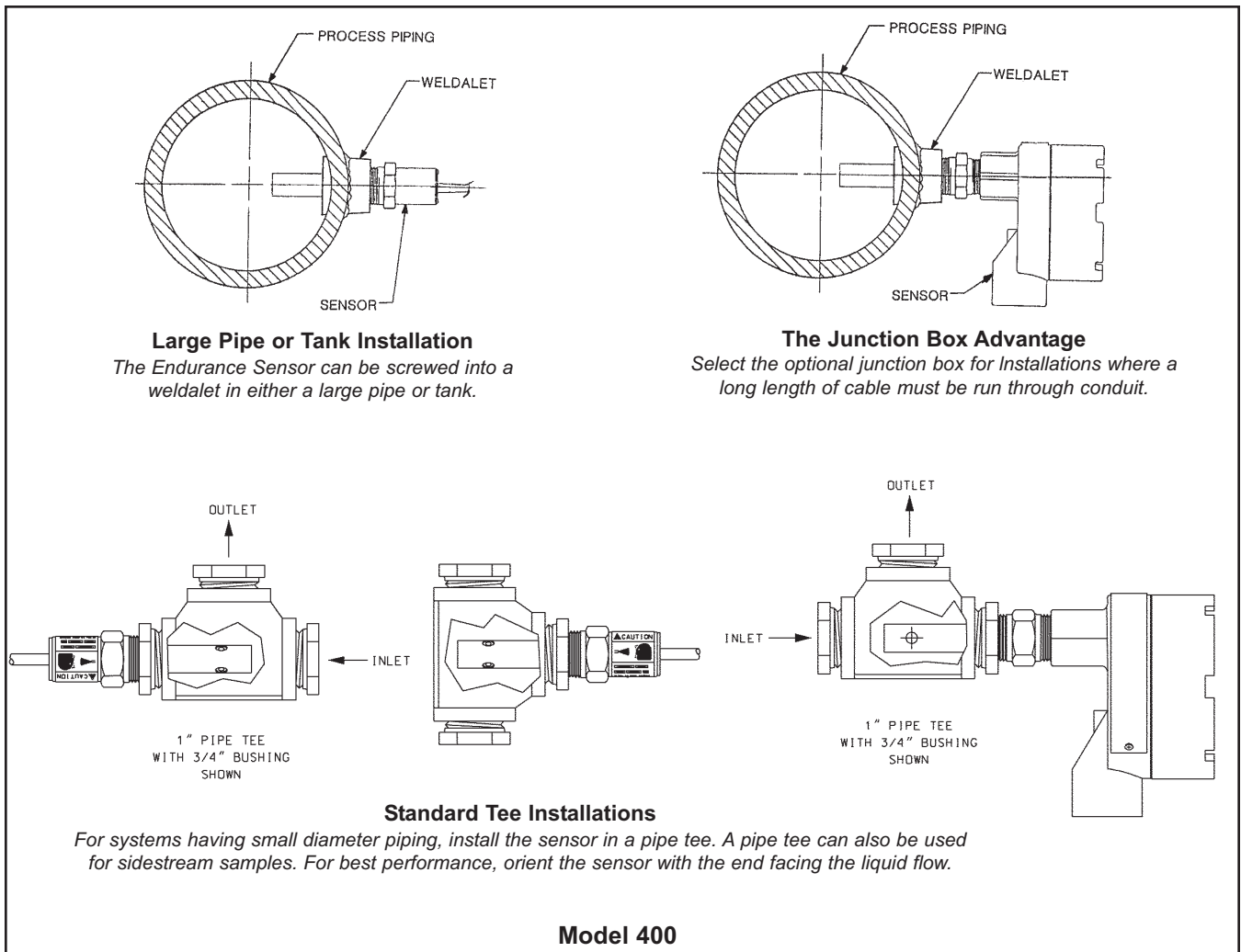
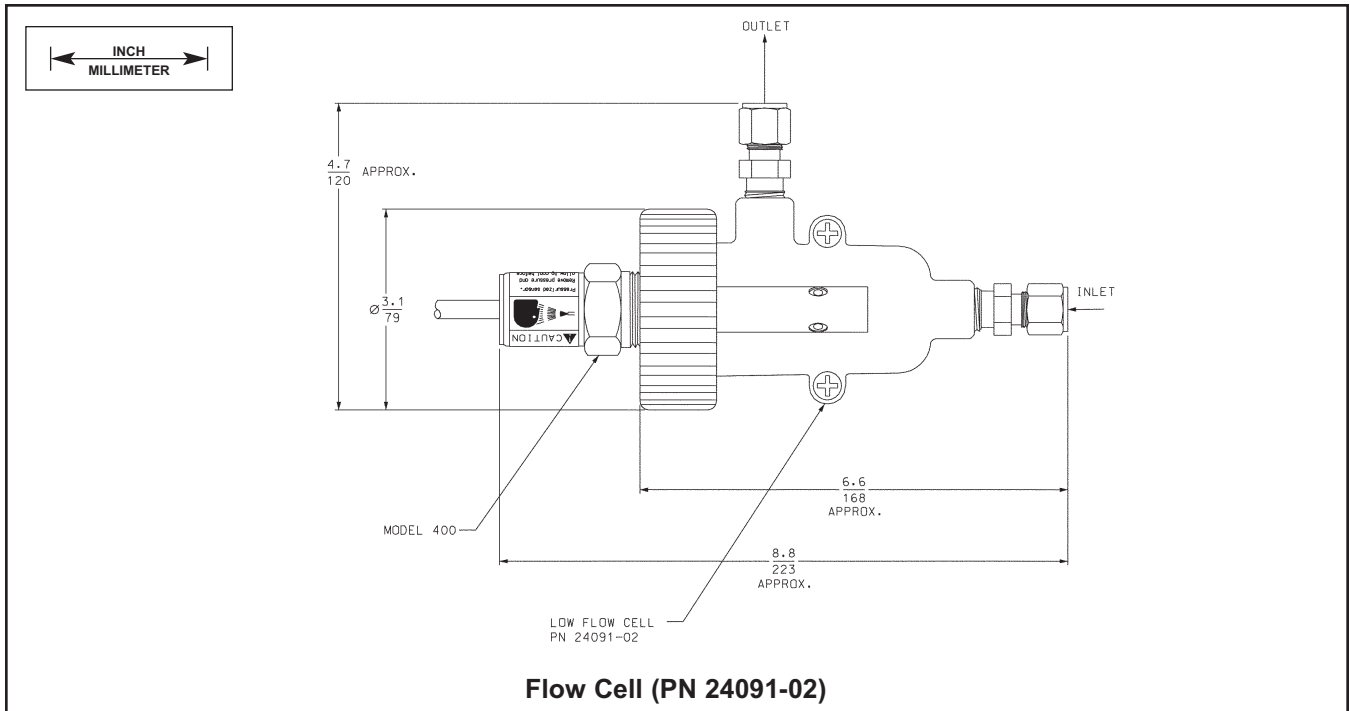



## INSTALLATION DETAILS

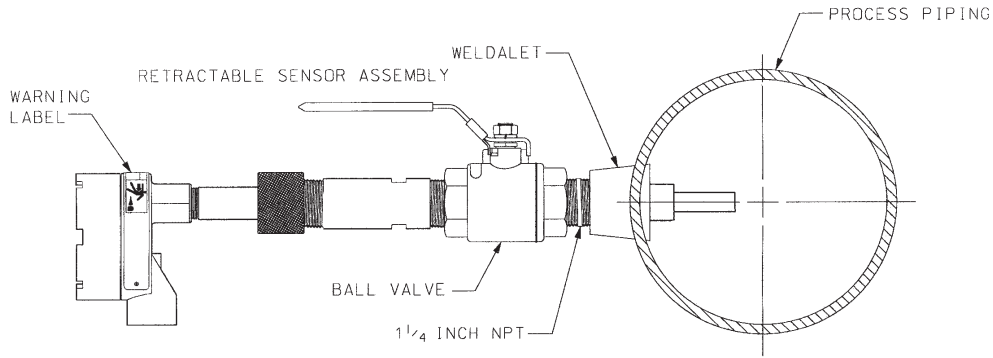

### Model 402 Retractable Sensor Installed In a Large Pipe or Tank

*The Endurance Retractable Sensor can be attached through a weldolet in either a large pipe or tank.*

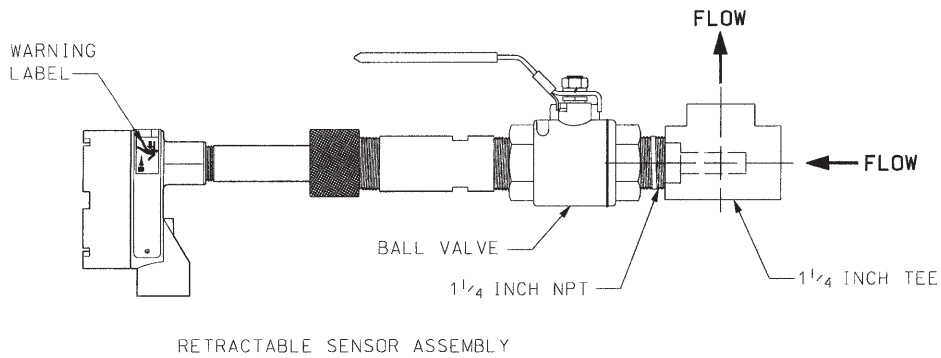

### Model 402 Retractable Sensor Installed In a Standard Tee

*For best performance, orient the sensor with the end facing the liquid flow.*

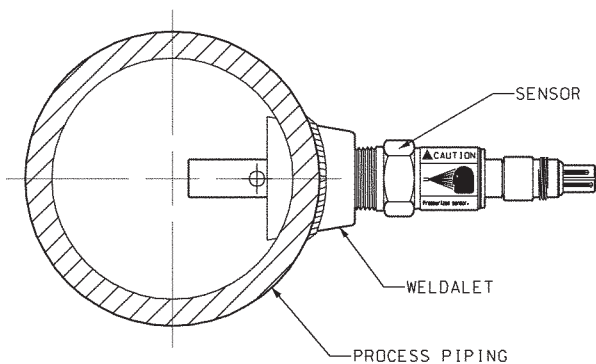

### Large Pipe or Tank Installation

*The Endurance Sensor can be screwed into a weldolet in either a large pipe or tank.*

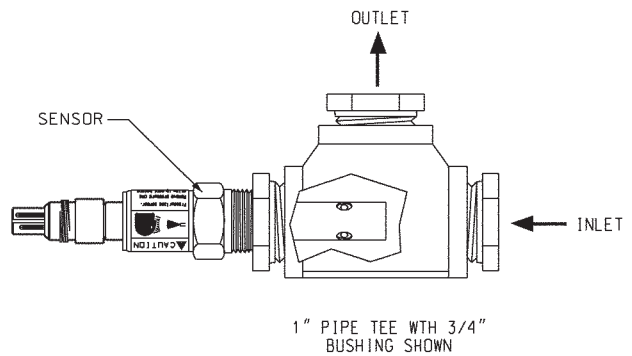

### Standard Tee Installations

*For systems having small diameter piping, install the sensor in a pipe tee. A pipe tee can also be used for sidestream samples. For best performance, orient the sensor with the end facing the liquid flow.*

## Model 400VP

## INSTALLATION DETAILS

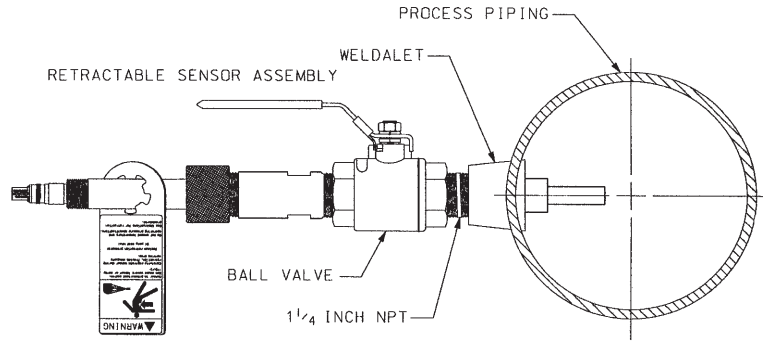

### Model 402VP Retractable Sensor Installed in a Large Pipe or Tank

The ENDURANCE Retractable Sensor can be attached through a weldolet in either a large pipe or tank.

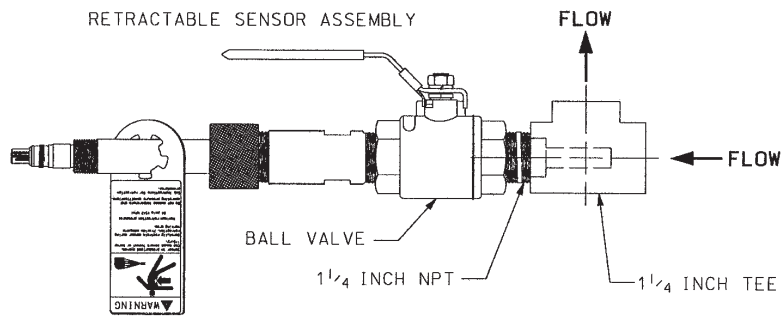

### Model 402VP Retractable Sensor Installed in a Standard Tee

For best performance, orient the sensor with the end facing the liquid flow.

**Model 402VP**

## ORDERING INFORMATION

**Model 400 Screw-in conductivity sensor** with integral cable is intended for the determination of electrolytic conductivity in clean water applications where the sensor can be screwed into the process piping or used in a pipe tee or flow cell in a sidestream.

MODEL 400 SCREW-IN CONDUCTIVITY SENSOR	
CODE	Cell Constant (required selection)
11	0.01/cm
12	0.1/cm
13	1.0/cm
CODE	Temperature Measurement
--	Pt 1000 for 1056, 56, 5081-C, 6081C, and 1066-C
CODE	Additional Options (optional selection)
36	Extended insertion length (5.5 in from bottom of threads to tip of sensor)
50	Extended cable length, 50 ft (15.2 m)
60	Integral junction box (required for high temperature applications) (See NOTE.)
<b>400</b>	<b>11 36</b> <b>EXAMPLE</b>

NOTE: Interconnecting cable between the junction box and analyzer must be purchased as a separate item. See **ACCESSORIES**.

**Model 400VP Screw-in conductivity sensor** with Variopol connector is intended for the determination of electrolytic conductivity in clean water applications where the sensor can be directly screwed into the process piping or used in a pipe tee or flow cell in a sidestream. **Interconnecting VP cable must be ordered separately and is required for all first time installations. See INTERCONNECTING VP CABLE on page 14.**

MODEL 400VP SCREW-IN CONDUCTIVITY SENSOR	
CODE	Cell Constant (required selection)
11	0.01/cm
12	0.1/cm
13	1.0/cm
CODE	Temperature Measurement
--	Pt 1000 for 1056, 56, 5081-C, 6081C, and 1066-C
CODE	Additional Options (optional selection)
36	Extended insertion length (5.5 in from bottom of threads to tip of sensor)
<b>400VP</b>	<b>11</b> <b>EXAMPLE</b>

**Model 402 Retractable conductivity sensor** with integral cable or junction box is intended for the determination of electrolytic conductivity in clean water applications where the ability to remove the sensor without shutting down the process or draining the line or tank is required.

<b>MODEL</b>	
<b>402 RETRACTABLE CONDUCTIVITY SENSOR</b>	
<b>CODE</b>	<b>Cell Constant (required selection)</b>
11	0.01/cm
12	0.1/cm
13	1.0/cm

<b>CODE</b>	<b>Temperature Measurement</b>
--	Pt 1000 for 1056, 56, 5081-C, 6081C, and 1066-C

<b>CODE</b>	<b>Additional Options (optional selection)</b>
31	Retraction assembly (nipple, ball valve, and retraction body)
60	Integral junction box (See NOTE.)
61	Sensor cable terminated for use with sensor junction box (See NOTE.)
<b>402</b>	<b>11 32 60 61 EXAMPLE</b>

NOTE: Interconnecting cable between the junction box and analyzer must be purchased as a separate item. See **ACCESSORIES**.

**Model 402VP Retractable conductivity sensor** with VP connector is intended for the determination of electrolytic conductivity in clean water applications where the ability to remove the sensor without shutting down the process or draining the line or tank is required. **Interconnecting VP cable must be ordered separately and is required for all first time installations. See INTERCONNECTING VP CABLE on page 14.**

MODEL	
<b>402VP</b>	<b>RETRACTABLE CONDUCTIVITY SENSOR</b>
CODE	Cell Constant (required selection)
11	0.01/cm
12	0.1/cm
13	1.0/cm
CODE	Temperature Measurement
--	Pt 1000 for 1056, 56, 5081-C, 6081C, and 1066-C
CODE	Additional Options (optional selection)
31	Retraction assembly (nipple, ball valve, and retraction body)
<b>402VP</b>	<b>12 31</b>
<b>EXAMPLE</b>	

**Model 404 Flow through conductivity sensor** is intended for the determination of electrolytic conductivity in clean water applications where rapid response to changes in conductivity or temperature is needed. The sensor must be used in a sidestream sample.

MODEL	
<b>404</b>	<b>FLOW THROUGH CONDUCTIVITY SENSOR</b>
CODE	Cell Constant (required selection)
11	0.01/cm
12	0.1/cm
CODE	Flow Cell body (required selection)
16	PVC
17	Stainless steel
CODE	Temperature Measurement
--	Pt 1000 for 1056, 56, 5081-C, 6081C, and 1066-C
CODE	Additional Options (optional selection)
50	Extended cable length, 50 ft (15.2 m)
<b>404</b>	<b>11 16</b>
<b>EXAMPLE</b>	

## ACCESSORIES for all models

Part Number	Description	Weight	Shipping Weight
23550-00	Junction box for remote cable connection	8 lb (4.0 kg)	9 lb (4.5 kg)
9200275	Connecting cable, unterminated, specify length	0.6 lb/10ft (1 kg/10 m)	Add 1 lb (0.5 kg)
23747-00	Connecting cable, terminated, specify length	0.6 lb/10ft (1 kg/10 m)	Add 1 lb (0.5 kg)
05010781899	Conductivity standard SS-6, 200 uS/cm, 32 oz (0.95 L)	3 lb (1.5 kg)	4 lb (2.0 kg)
05010797875	Conductivity standard SS-6A, 200 uS/cm, 1 gal (3.78 L)	9 lb (4.5 kg)	10 lb (4.5 kg)
05010782468	Conductivity standard SS-5, 1000 uS/cm, 32 oz (0.95 L)	3 lb (1.5 kg)	4 lb (2.0 kg)
05010783002	Conductivity standard SS-5A, 1000 uS/cm, 1 gal (3.78 L)	9 lb (4.5 kg)	10 lb (4.5 kg)
05000705464	Conductivity standard SS-1, 1409 uS/cm, 32 oz (0.95 L)	3 lb (1.5 kg)	4 lb (2.0 kg)
05000709672	Conductivity standard SS-1A, 1409 uS/cm, 1 gal (3.78 L)	9 lb (4.5 kg)	10 lb (4.5 kg)
05010782147	Conductivity standard SS-7, 5000 uS/cm, 32 oz (0.95 L)	3 lb (1.5 kg)	4 lb (2.0 kg)
05010782026	Conductivity standard SS-7A, 5000 uS/cm, 1 gal (3.78 L)	9 lb (4.5 kg)	10 lb (4.5 kg)

## ACCESSORIES for Model 400 and 400VP

Part Number	Description	Weight	Shipping Weight
24091-02	Flow cell, accepts sensor with 3/4-inch MNPT	1 lb (0.5 kg)	2 lb (1.0 kg)

## ACCESSORIES for Model 402 and 402VP

Part Number	Description	Weight	Shipping Weight
23765-00	Retraction assembly kit (includes nipple, ball valve, and retraction body)	8 lb.(4.0kg)	98 lb (4.5 kg)
23796-00	Retraction body from retraction assembly kit (excludes ball valve and nipple)	4 lb (2 kg)	5 lb (2.5 kg)
9340078	1 1/4 inch NPT full port ball valve		

## INTERCONNECTING VP CABLE for 400VP and 402VP sensor

Part Number	Description	Weight	Shipping Weight
23747-06	Interconnecting cable, VP 6, 2.5 ft (0.8 m)	1 lb (0.5 kg)	Add 1 lb (0.5 kg)
23747-04	Interconnecting cable, VP 6, 4 ft (1.2m)	1 lb (0.5 kg)	Add 1 lb (0.5 kg)
23747-02	Interconnecting cable, VP 6, 10 ft (3.0 m)	1 lb (0.5 kg)	Add 1 lb (0.5 kg)
23747-07	Interconnecting cable, VP 6, 15 ft (4.6 m)	2 lb (1.0 kg)	Add 1 lb (0.5 kg)
23747-08	Interconnecting cable, VP 6, 20 ft (6.1 m)	2 lb (1.0 kg)	Add 1 lb (0.5 kg)
23747-09	Interconnecting cable, VP 6, 25 ft (7.6 m)	2 lb (1.0 kg)	Add 1 lb (0.5 kg)
23747-10	Interconnecting cable, VP 6, 30 ft (9.1 m)	2 lb (1.0 kg)	Add 1 lb (0.5 kg)
23747-03	Interconnecting cable, VP 6, 50 ft (15.2 m)	4 lb (2.0 kg)	Add 1 lb (0.5 kg)
23747-11	Interconnecting cable, VP 6, 100 ft (30.5 m)	8 lb (4.0 kg)	Add 1 lb (0.5 kg)

## ENGINEERING SPECIFICATIONS

### Engineering Specification for 400 and 400VP sensor (Cell constants 0.01, 0.1, and 1.0/cm)

1. The sensor shall be suitable for the determination of electrolytic conductivity in clean, non-corrosive samples.
2. The sensor shall have a 3/4- inch MNPT fitting for direct insertion into pipes or tees. A clear plastic flow cell shall also be available for side-stream samples.
3. The sensor shall incorporate titanium electrodes and a PEEK insulator.
4. The sensor shall have an integral platinum RTD for temperature measurement.
5. The sensor shall be available with either integral cable or a Variopol quick disconnect fitting.
6. The maximum temperature for the sensor shall be 221°F (105°C) at 250 psig (1825 kPa abs). A high temperature option that can be used at 392°F (200°C) shall also be available.
7. The sensor shall be suitable for vacuum service as low as 1.6 in Hg (5.2 kPa).
8. The sensor shall be Rosemount Analytical Model 400 (integral cable) or 400VP (Variopol fitting) or approved equal.

### Engineering Specification for 402 and 402VP sensor (Cell constants 0.01, 0.1, and 1.0/cm)

1. The sensor shall be suitable for the determination of electrolytic conductivity in clean, non-corrosive samples where the ability to remove the sensor from the process piping or tank without shutting down or draining lines or equipment is desired.
2. The sensor shall be supplied with a retraction assembly and full port ball valve. The ball valve shall be connected to the piping or tank using a 1-1/4 inch close nipple.
3. The sensor shall incorporate titanium electrodes and a PEEK insulator.
4. The sensor shall have an integral platinum RTD for temperature measurement.
5. The sensor insertion tube shall be 316 stainless steel.
6. The ball valve shall be 316 stainless steel with

Teflon seals and seats.

7. The retraction body shall be 316 stainless steel and shall use three graphite packing rings to seal the sensor tube.
8. The maximum temperature for the sensor shall be 212°F (100°C) at 200 psig (1481 kPa abs).
9. The maximum retraction pressure shall be 64 psig (542 kPa abs).
10. The sensor shall be suitable for vacuum service as low as 1.6 in Hg (5.2 kPa).
11. The sensor shall be available with integral cable, integral junction box, or a Variopol quick disconnect fitting.
12. The sensor shall be Rosemount Analytical Model 402 (integral cable) or 402VP (Variopol fitting) or approved equal.

### Engineering Specification for 404 Sensor (0.01 and 0.1/cm cell constants)

1. The sensor shall be suitable for the determination of electrolytic conductivity in clean, non-corrosive sidestream samples where rapid response to changes in conductivity or temperature is needed.
2. The sensor shall incorporate titanium electrodes and a PEEK insulator.
3. The sensor shall have an integral platinum RTD for temperature measurement.
4. The sensor shall be available with either a PVC or stainless steel body flow cell
5. The PVC body sensor shall have 3/8-inch barbed tubing connectors.
6. The stainless steel body sensor shall have compression fittings for 3/8-inch OD tubing. The compression fittings shall be removable to leave 1/4-inch FNPT ports.
7. The maximum temperature for the PVC body sensor shall be 140°F (60°C) at 20 psig (239 kPa abs).
8. The maximum temperature for the stainless steel body sensor shall be 212°F (100°C) at 100 psig (791 kPa abs).
9. The sensor shall be Rosemount Analytical Model 404 or approved equal.



## COMPATIBLE ANALYZERS AND TRANSMITTERS

**The Model 1056 Dual Input Analyzer** can be used with any ENDURANCE family conductivity sensor to measure electrolytic conductivity in a variety of applications. The Model 1056 can be set up as either a dual input conductivity analyzer, or the second input can be connected to a pH, ORP, chlorine, oxygen, ozone, or turbidity sensor. The analyzer has two fully programmable analog outputs. Four fully programmable alarm relays are available as an option. The high contrast display shows measurement results in large, easy-to-read digits. Menu screens for programming are simple and intuitive. Plain language prompts (in seven languages) guide the user. The analyzer continuously monitors itself and the sensor for faults and alerts the user when it detects a problem. HART and Profibus digital communications are optional. HART allows the user to communicate with the analyzer through AMS (Asset Management Solutions) from a host anywhere in the plant.



**The Model 56 Analyzer** can be used with any ENDURANCE family conductivity sensor to measure electrolytic conductivity in a variety of applications. The Model 56 can be set up as either a dual input conductivity analyzer, or the second input can be connected to a pH, ORP, chlorine, oxygen, ozone, or turbidity sensor. The analyzer has four fully programmable analog outputs and four fully programmable alarm relays, including PID and TPC control. The high contrast, full color display shows measurement results in large, easy-to-read digits. Menu screens for programming and calibration are simple and intuitive. Information screens, offering detailed explanation of programming features and calibration methods as well as troubleshooting assistance, are available at the touch of a button. An event and data logger and a dual graphical display are also standard. HART and Profibus DP digital communication are optional.



**The Model 5081-C Transmitter** can be used with any ENDURANCE family conductivity sensor to measure electrolytic conductivity in a variety of applications, particularly where a robust, explosion-proof instrument enclosure and loop power are needed. The conductivity reading is shown in large numerals in the top line of a two-line, seven-segment display. Local communication with the 5081-C is through a handheld infrared remote controller. Two digital communication protocols are available: HART and Foundation Fieldbus. Digital communications allows the user to communicate with the transmitter through AMS (Asset Management Solutions) from a host anywhere in the plant.



**The Model 1066-C Transmitter** can be used with any ENDURANCE family conductivity sensor to measure electrolytic conductivity in a variety of applications, particularly in applications where loop power is needed. The 1066-C has a large easy-to-read display that can be configured to meet user requirements. Menu screens (in eight languages) for configuring and calibrating are simple and intuitive. Two digital communication protocols, HART and Foundation fieldbus, are available. Digital communications allows the user to communicate with the transmitter through AMS (Asset Management Solutions) from a host anywhere in the plant.



**All Rosemount Analytical Conductivity Instruments** feature automatic temperature corrections for high purity water and cation conductivity. Programmable percent change per °C temperature correction is also available.



*The right people,  
the right answers,  
right now.*

ROSEMOUNT ANALYTICAL  
CUSTOMER SUPPORT CENTER  
1-800-854-8257

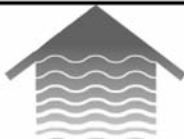

ON-LINE ORDERING NOW AVAILABLE ON OUR WEB SITE  
<http://www.rosemountanalytical.com>

*Specifications subject to change without notice.*



Credit Cards for U.S. Purchases Only.



### Emerson Process Management

2400 Barranca Parkway  
Irvine, CA 92606 USA  
Tel: (949) 757-8500  
Fax: (949) 474-7250

<http://www.rosemountanalytical.com>

© Rosemount Analytical Inc. 2013

