

Dissolved Ozone Sensor

- RUGGED CONSTRUCTION.
- EASILY REPLACEABLE MEMBRANE; no special tools required.
- AUTOMATIC COMPENSATION for changes in membrane permeability with temperature.
- AUTOMATIC PRESSURE EQUALIZATION maintains correct membrane tension.
- VARIOPOL CONNECTOR OPTION allows the sensor to be replaced without running new cable.



FEATURES AND APPLICATIONS

The 499AOZ sensor is intended for the continuous determination of dissolved ozone. The primary application is ozonation basins in municipal water filter plants. Ozone is also used as a disinfectant in bottling and food processing plants.

The 499AOZ is a membrane-covered amperometric sensor. The sensor consists of a gas-permeable membrane stretched tightly over a gold cathode. A silver anode and an electrolyte solution complete the internal circuit. During operation, ozone diffuses from the sample through the membrane. Once inside the sensor, the ozone reacts with the electrolyte solution to form an intermediate compound. A polarizing voltage applied to the cathode completely reduces the intermediate. The reduction produces a current, which the analyzer measures. The current is directly proportional to the rate at which ozone diffuses through the membrane, which is ultimately proportional to the concentration of ozone in the sample.

Because the rate of diffusion of ozone through the membrane depends on temperature, sensor response must be corrected for temperature changes. A Pt 100 RTD in the sensor measures the temperature, and the analyzer automatically performs the correction.

Because ozone standards do not exist, the sensor must be calibrated against the results of a laboratory test run on a grab sample of the process liquid. Ozone solutions are unstable, so the sample must be tested

immediately. Portable test kits are available from other manufacturers.

Maintenance is fast and easy. Replacing the membrane requires no special tools or fixtures. Simply place a few drops of electrolyte solution in the membrane assembly, place it over the cathode, and screw the retainer in place. To replenish the electrolyte solution, unscrew the fill plug, add the reagent from a squeeze bottle, and replace the plug.

Pressure changes have little influence on sensor response. A flexible bladder in the sensor prevents distortion of the membrane by keeping the pressure inside the sensor equal to the sample pressure.

Several mounting configurations are possible. For most applications the low flow cell is recommended.

The Model 499AOZ sensor is available with a Variopol (VP) watertight connector. Wire the interconnecting cable to the analyzer and run the cable to the sensor. The sensor plugs into the cable receptacle. To replace the sensor, simply disconnect the Variopol fitting and plug in a new sensor.

SENSOR SPECIFICATIONS

Range: 0 to 3 ppm (mg/L) as O₃.

Wetted Parts: Polysulfone, Viton¹, Teflon², silicone

Cathode: gold (not normally wetted)

Accuracy: Accuracy depends on the accuracy of the chemical test used to calibrate the sensor.

Linearity: ±5% of reading or ±3 ppb (whichever is greater) at 25°C

Repeatability: ±2% of reading at constant temperature

Response time: 30 sec to 90% of final reading at 25°C

Pressure: 0 to 65 psig (101 to 549 kPa abs)

Temperature (Operating): 32 to 122°F (0 to 50°C)

Membrane Permeability Correction:

Defined between 41 and 95°F (5 and 35°F)

Process Connection: 1 inch MNPT

Electrolyte Volume: 25 mL (approx.)

Electrolyte Life: 3 months (approx.); for best results, replace electrolyte monthly

Cable Length (standard integral cable): 25 ft (7.6 m)

Cable Length (maximum): 300 ft (91 m)

Sample Flow:

| | |
|---------------|-----------------------------|
| Flow through | 1-5 gpm (3.8 to 19 L/min) |
| Open channel | 1 ft/sec (0.3 m/sec) |
| Low flow cell | 2 to 5 gph (7.6 to 19 L/hr) |

Weight/Shipping Weight: 1 lb/3 lb (0.5 kg/1.5 kg)

Weight and shipping weight are rounded up to the nearest whole pound or 0.5kg.

¹ Viton is a registered trademark of E.I. duPont de Nemours & Co.

² Teflon is a registered trademark of E.I. duPont de Nemours & Co.

OTHER SPECIFICATIONS

LOW FLOW CELL PN 24091-00

Wetted Parts: polycarbonate, polyester, 316 stainless steel, silicone

Process Connection: 1/4-inch OD tubing compression fitting or 1/4-inch FNPT

Maximum Pressure: 90 psig (722 kPa abs)

Maximum Temperature: 158°F (70°C)

Note: The temperature and pressure specifications for the low flow cell exceed the specifications for the sensor.

FLOW-THROUGH TEE (1½ inch body) PN 23567-00

Wetted Parts: CPVC and Buna N; body is schedule 80 CPVC

Process Connection: 1-½ inch socket

Maximum Pressure: 65 psig (549 kPa abs)

Maximum Temperature: 122°F (50°C)

FLOW-THROUGH TEE (2 in. body) PN 915240-03/04/05

Wetted Parts: PVC and Buna N; body is schedule 80 PVC

Process Connection: ¾ inch NFPT, 1 inch NFPT, or 1½ inch NFPT

Maximum Pressure: 60 psig (515 kPa abs)

Maximum Temperature: 120°F (49°C)

VALVED ROTAMETER PN 9390004

for use with Low Flow Cell

Flow: 0.4 to 5 gph (1.5 to 19 L/hr)

Wetted Parts: acrylic, 316 stainless steel, Viton

Process Connection: ¼ inch NFPT (316 SS)

Maximum Pressure: 100 psig (858 kPa abs)

Maximum Temperature: 150°F (65°C)

RECOMMENDED ANALYZERS

Rosemount Analytical Models 1056, 56, 54eA, 5081-A, 1066, and Xmt-A.

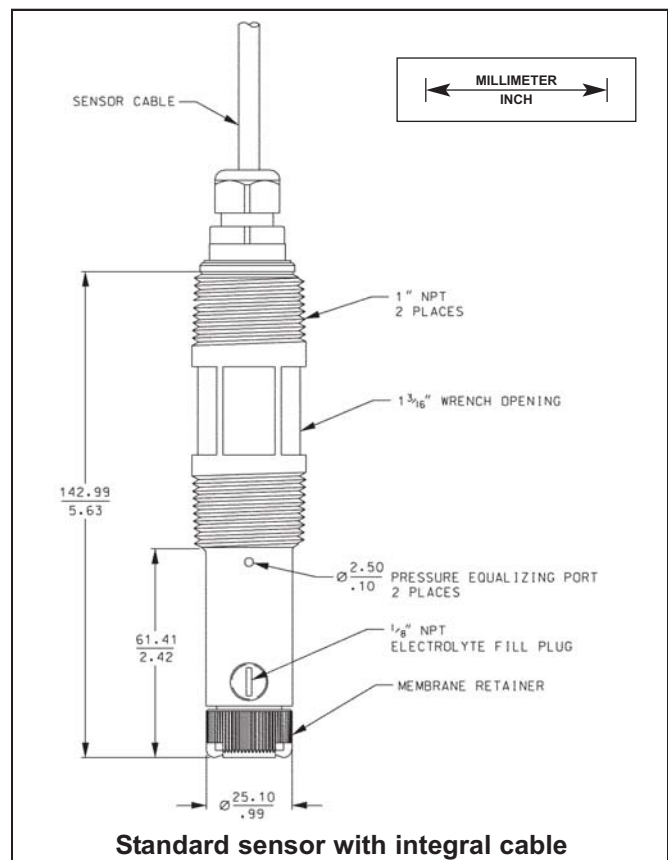

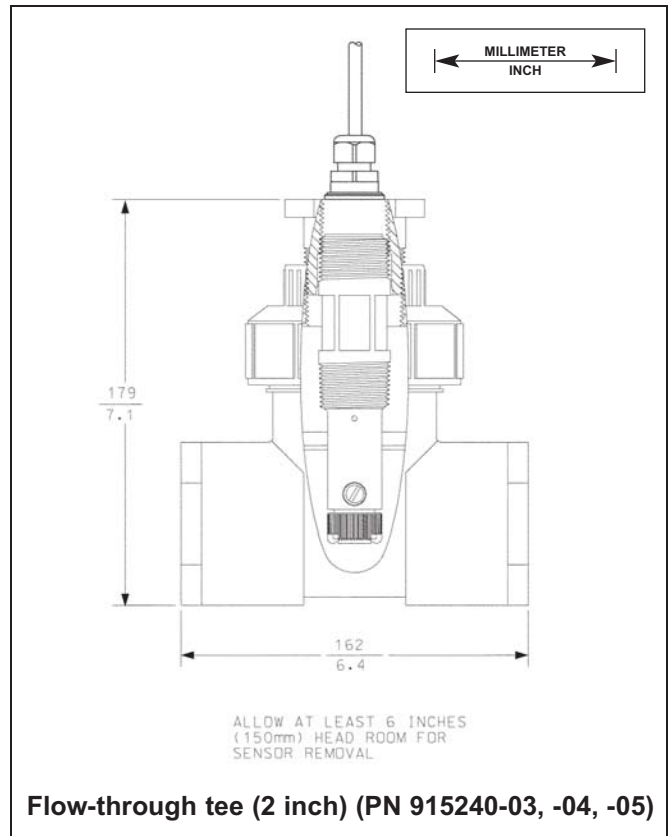
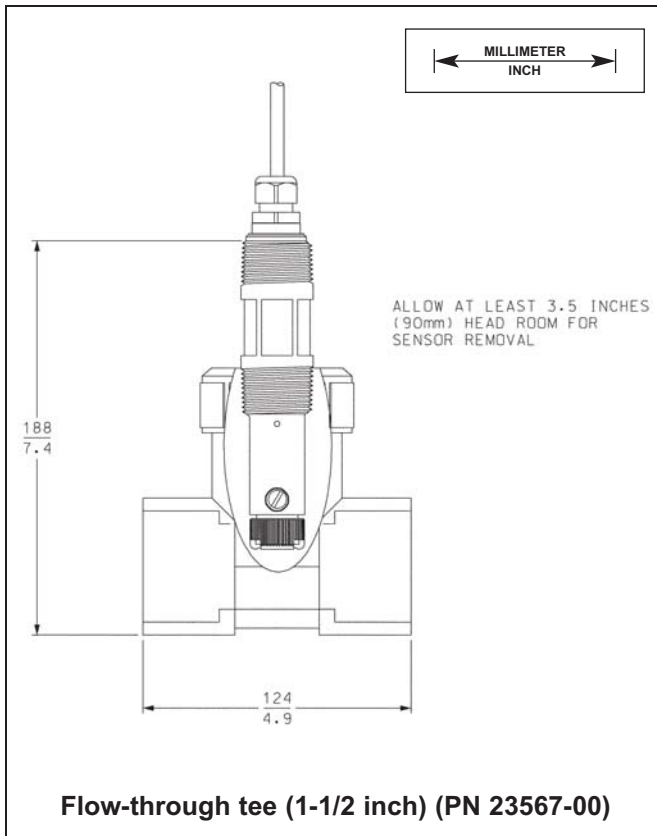
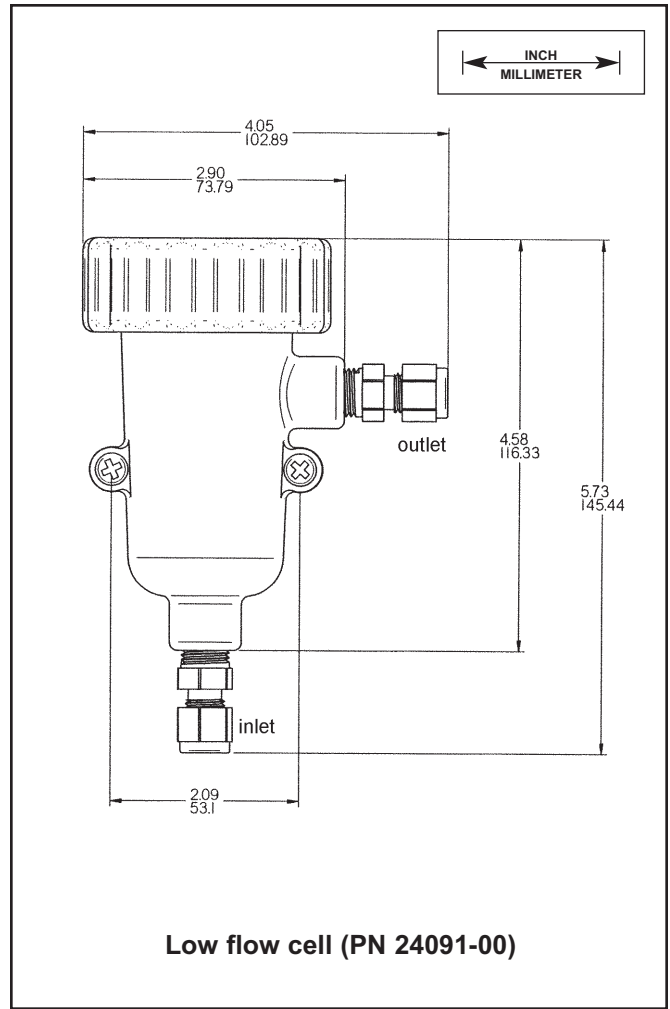
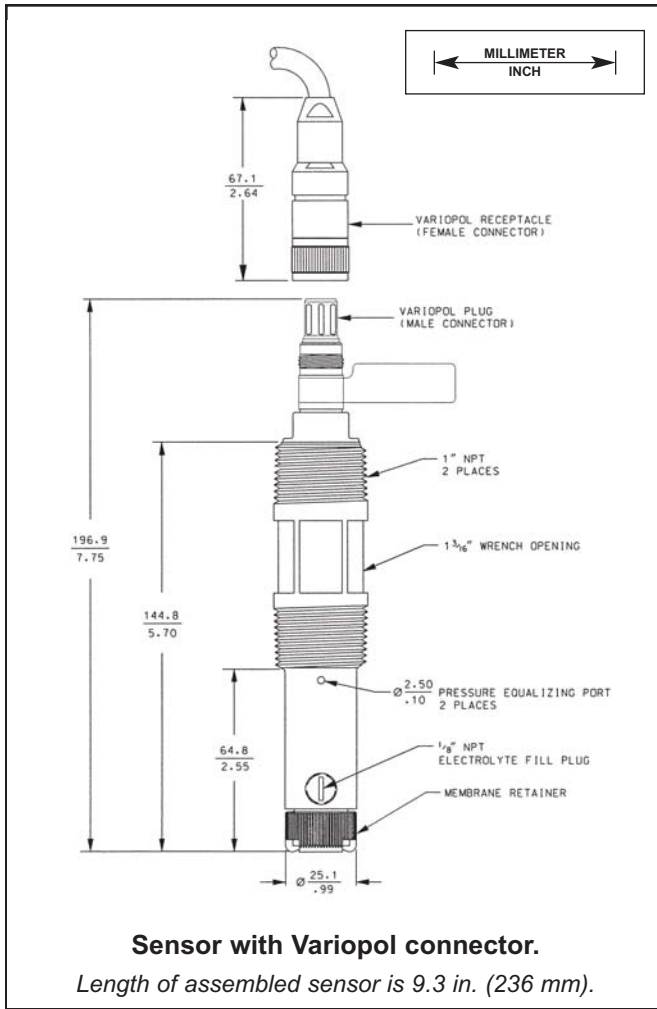

ORDERING INFORMATION

The **Model 499AOZ sensor** is intended for the determination of dissolved ozone in a variety of municipal and industrial applications. The sensor is generally intended for mounting in an off-line flow cell. The sensor is available with either an integral cable or a VP6 quick disconnect fitting. Three replacement membrane assemblies, three o-rings and a 4-oz (125 mL) bottle of electrolyte solution are provided with each sensor.

| MODEL 499AOZ DISSOLVED OZONE SENSOR | |
|-------------------------------------|---|
| CODE | Required selection |
| 54 | For use with Model 1056, 56, 54eA, 5081-A, 1066, and Xmt-A analyzers |
| CODE | Optional selection |
| 60 | Optimum EMI/RFI cable (not available with -VP options) |
| VP | Sensor with Variopol 6 connector (interconnecting cable must be ordered separately) |
| 499AOZ | -54 -VP EXAMPLE |

FOR FIRST TIME VARIOPOL INSTALLATIONS

| PART # | DESCRIPTION | PART # | DESCRIPTION |
|----------|---|----------|--|
| 23747-06 | Interconnecting cable, VP 6, 2.5 ft (0.8 m) | 23747-09 | Interconnecting cable, VP 6, 25 ft (7.6 m) |
| 23747-04 | Interconnecting cable, VP 6, 4 ft (1.2m) | 23747-10 | Interconnecting cable, VP 6, 30 ft (9.1 m) |
| 23747-02 | Interconnecting cable, VP 6, 10 ft (3.0 m) | 23747-03 | Interconnecting cable, VP 6, 50 ft (15.2 m) |
| 23747-07 | Interconnecting cable, VP 6, 15 ft (4.6 m) | 23747-11 | Interconnecting cable, VP 6, 100 ft (30.5 m) |
| 23747-08 | Interconnecting cable, VP 6, 20 ft (6.1 m) | | |

ACCESSORIES

| PART # | DESCRIPTION |
|-----------|--|
| 23567-00 | 1-½ in. flow through tee with 1-½ socket connections |
| 915240-03 | 2-in. flow through tee with ¾-in FNPT connections |
| 915240-04 | 2-in. flow through tee with 1-in FNPT connections |
| 915240-05 | 2-in. flow through tee with 1-½-in FNPT connections |
| 24091-00 | Low flow cell with ¼-in OD tubing compression fittings |
| 9390004 | Rotameter: 0.5 - 5.0 gph |
| 22550-00 | Junction box, 12 terminals |
| 9200266 | Extension cable for option -54, unterminated (specify length) |
| 9200275 | Extension cable for optimum EMI/RFI cable, unterminated (specify length) |
| 23747-00 | Extension cable for optimum EMI/RFI cable, terminated (specify length) |
| 2001492 | Stainless steel tag |
| 23501-11 | Dissolved ozone membrane assembly: includes one membrane assembly and O-ring. |
| 23502-11 | Dissolved ozone membrane assembly: includes three membrane assemblies and three O-rings. |
| 9210299 | #3 Dissolved ozone sensor fill solution, 4 oz (125 mL) |



*The right people,
the right answers,
right now.*

ROSEMOUNT ANALYTICAL
CUSTOMER SUPPORT CENTER
1-800-854-8257

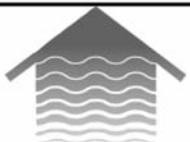

ON-LINE ORDERING NOW AVAILABLE ON OUR WEB SITE
<http://www.rosemountanalytical.com>

Specifications subject to change without notice.



Credit Cards for U.S. Purchases Only.



Emerson Process Management

2400 Barranca Parkway
Irvine, CA 92606 USA
Tel: (949) 757-8500
Fax: (949) 474-7250

<http://www.rosemountanalytical.com>

© Rosemount Analytical Inc. 2015

